

Product Catalog for Paper Manufacturing Machinery

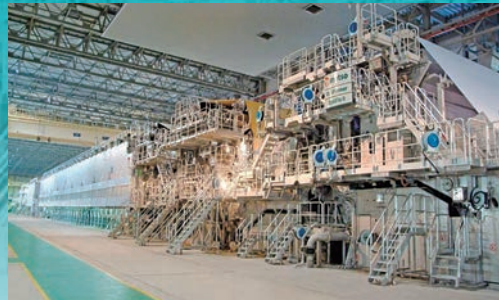

Products for Paper Manufacturing Machinery

Photo : Ishinomaki Mill, Nippon Paper Industries Co., Ltd.

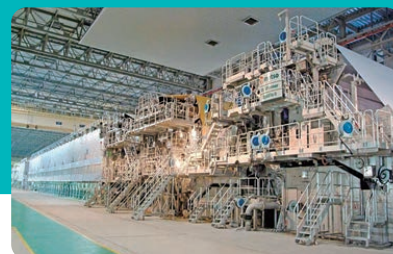

INDEX

	Ref. Page
ULTAGE Series Spherical Roller Bearings [Type EA, Type EM]	P5 P7 ~ 8
ULTAGE Series Sealed Spherical Roller Bearings [Type WA], Plummer Blocks	P6
RustGuard Corrosion-Resistant Bearings	P9 ~ 10
Long Operating Life Bearings – EA Type	P11 ~ 12
Solid Grease Bearings	P13 ~ 14
MEGAOHM™ Insulated Bearings	P15
Triple-Lip Sealed Bearings for Bearing Units	P16
ULTAGE Series Thrust Spherical Roller Bearings	P17 ~ 18
Constant Velocity Joints	P19 ~ 20
Size Charts	P21 ~ 34
Inspecting and Maintaining Bearings, Installing Tapered Bore Roller Bearings	P35 ~ 36
Bearing Damage – Typical Examples & Causes	P37 ~ 38

Related Catalogs

	Cat. No.
Ball and Roller Bearings	2202/E
ULTAGE Series Spherical Roller Bearings [Type EA, Type EM]	3033/E
ULTAGE Series Sealed Spherical Roller Bearings [Type WA]	3703/E
ULTAGE Series Thrust Spherical Roller Bearings	3034/E
Large Size, Long Operating Life EA Bearing	3024/E
Solid Grease Bearings	3022/E
MEGAOHM™ Insulated Bearings	3030/E
Bearing Units	2400/E
Triple-Lip Sealed Bearings for Bearing Units	3905/E
Plummer Blocks	2500/E
Constant Velocity Joints for Industrial Machinery	5603/E
TRI-BALL JOINT Constant Velocity Joints (Small and Medium size)	5602/E
Care and Maintenance of Bearings	3017/E

For stable, high reliability performance...

The paper making process requires bearings having specific capabilities for each part of the process. **NTN** ensures reliable paper production by providing bearings that are optimally suited for each process.

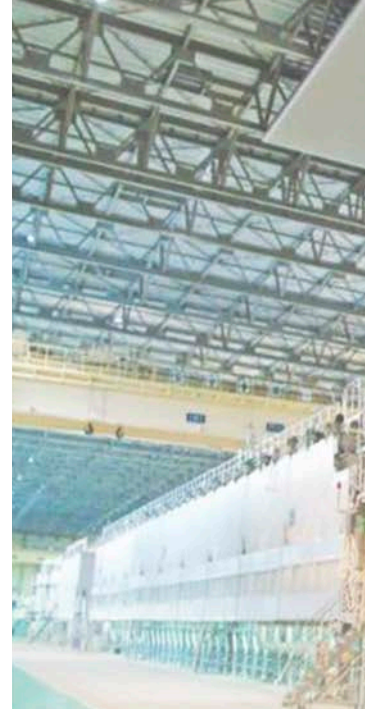

Pulp Manufacturing Process

Paper Machine Wire Section

Paper Machine Press Section

Paper formation begins by dewatering the paper stock feed

Additional water is removed from the wet paper sheet by the press rolls

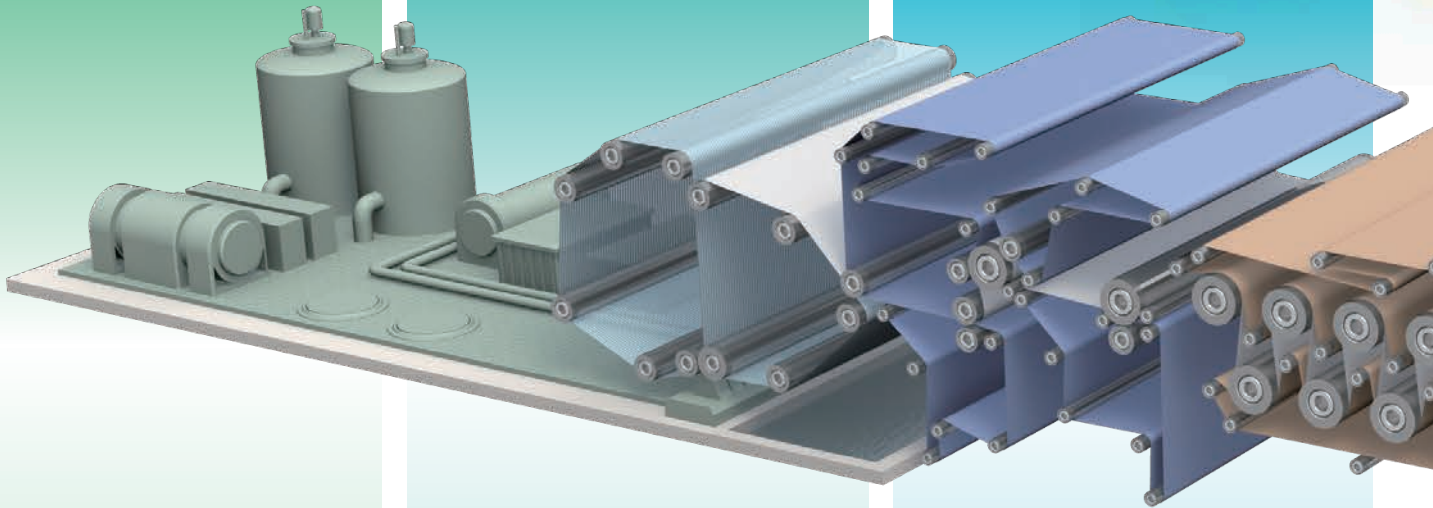

- ❶ ULTAGE series sealed spherical roller bearings [Type WA]
- ❷ ULTAGE series thrust spherical roller bearings
- ❸ Solid grease bearings
- ❹ Triple-Lip sealed bearings for bearing units

- ❸ ULTAGE series spherical roller bearings [Type EA, Type EM]
- ❹ RustGuard corrosion-resistant bearings
- ❷ Solid grease bearings
- ❸ Constant velocity joints

- ❸ ULTAGE series spherical roller bearings [Type EA, Type EM]
- ❹ RustGuard corrosion-resistant bearings
- ❺ MEGAOHM™ insulated bearings
- ❷ Solid grease bearings
- ❸ Constant velocity joints



ULTAGE series sealed spherical roller bearings [Type WA]



ULTAGE series thrust spherical roller bearings



ULTAGE series spherical roller bearings [Type EA, Type EM]



RustGuard corrosion-resistant bearings



Paper Machine Dryer Section & Size Press

Paper sheet drying is completed and coatings are applied by the size press

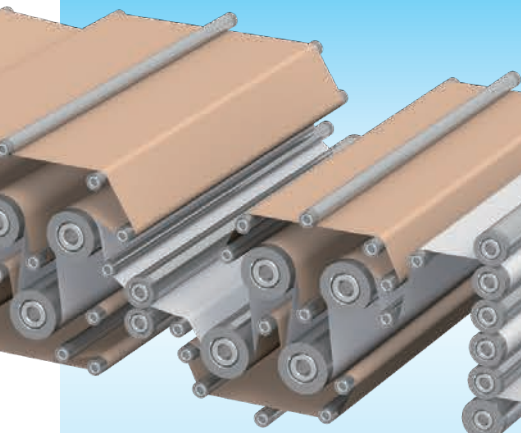

- ③ ULTAGE series spherical roller bearings [Type EA, Type EM]
- ⑥ Long operating life EA bearings
- ⑧ Constant velocity joints

Calender Stack

Rolls produce a smooth, glossy paper surface

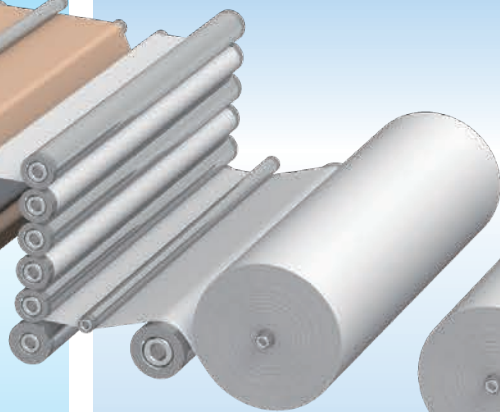

- ③ ULTAGE series spherical roller bearings [Type EA, Type EM]
- ⑦ Solid grease bearings
- ⑧ Constant velocity joints

Reel & Winder

Main paper take-up roll and rewinding into smaller size rolls

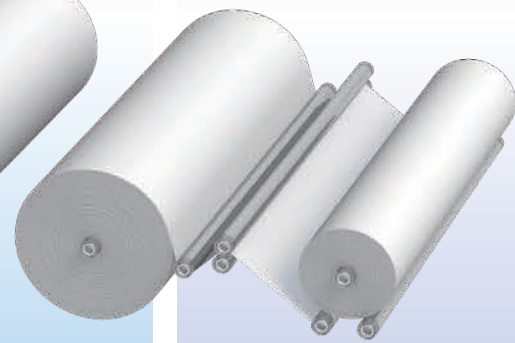

- ③ ULTAGE series spherical roller bearings [Type EA, Type EM]
- ⑦ Solid grease bearings
- ⑧ Constant velocity joints



5 MEGA OHM™ insulated bearings



6 Long operating life EA bearings



7 Solid grease bearings



8 Constant velocity joints



9 Triple-Lip sealed bearings for bearing units

ULTAGE

ULTAGE Series

Spherical Roller Bearings [Type EA, Type EM]



Long operating life, higher load capacities and enhanced high-speed operation provide maximum equipment productivity

Construction

Type EA

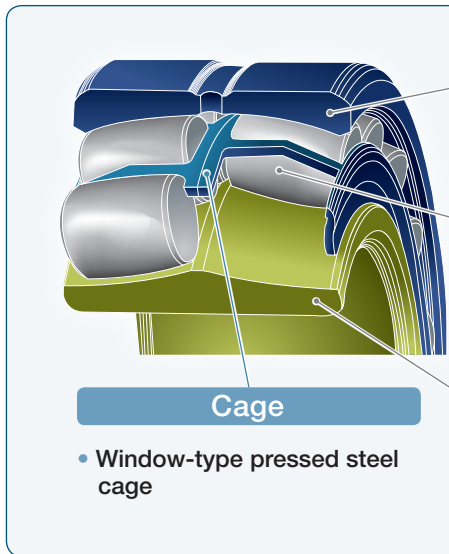

- Window-type pressed steel cage

Outer ring

- With oil inlets and oil groove
- Optimal curvature

Rollers

- Symmetrical design
- Larger rollers
- Maximum number of rollers

Inner ring

- No rib required
- Optimal curvature

Type EM

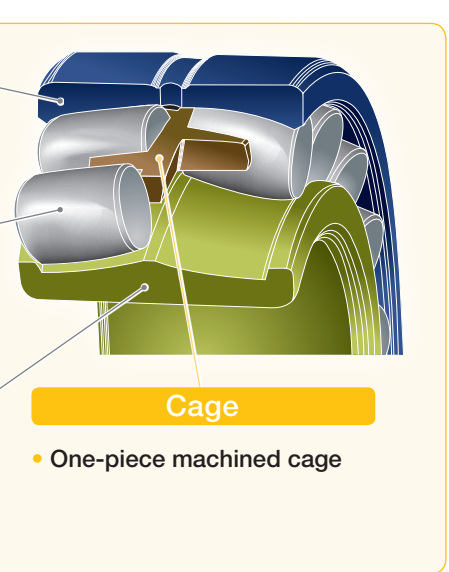

Cage

- One-piece machined cage

Features

● High-load capacity

By using larger diameter, increased number of rollers...

Basic dynamic load rating
Up to **65% higher**
(compared to NTN conventional products)

Basic static load rating
Up to **35% higher**
(compared to NTN conventional products)

● High-speed performance

By using optimized curvatures and a new retainer design...

Maximum shaft speed
Up to **20% higher**
(compared to NTN conventional products)

● Long operating life

By increasing the load capacity...

Operating life
Up to **5 times longer**
(compared to NTN conventional products)

● Heat-resistant performance

By using advanced material heat treatment technology...

Dimensional stability
Up to **200°C**

Refer to the technical data (p-7)

Refer to the size charts (p-21)

"ULTAGE" (a name created from the combination of "Ultimate," signifying refinement, and "stage," signifying NTN's intention that this series of products be employed in diverse applications) is the general name for NTN's new generation of bearings that are noted for their industry-leading performance.

ULTAGE

ULTAGE Series

Sealed Spherical Roller Bearings [Type WA]



Features

High performance sealing

Long operating life with high contamination resistance is achieved by using the **NTN EA** internal specifications with a specially designed contact-type rubber seal.

Interchangeability

Can be installed into standard type plummer blocks by adjusting fixing ring size.

Bearing Specifications

Lubricant grease

- Lubricate with lithium based oil grease containing extreme pressure additives
- Grease pack amount : 15 to 25% of space capacity

Premitted rotational speed

- When re-lubricating : $dn \leq 60 \times 10^3$
- When not re-lubricating : $dn \leq 80 \times 10^3$

$[dn = d \text{ (bearing bore diameter [mm])} \times n \text{ (shaft speed [min}^{-1}\text{)}]$

Premissible alignment angle

- 0.009 rad (0.5°)

Premissible operating temperature range

- Bearing temperature : -20 to 110°C

[Bearing rotation torque test conditions]

Bearing : WA22218EALLSD1
 Load : Radial load 294N
 Shaft speed : 200 - 1400 min⁻¹
 Lubrication : Lithium based grease containing extreme pressure additives

Grease pack amount : 20% of space capacity

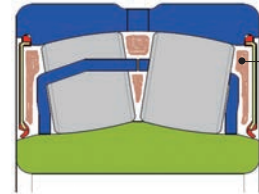
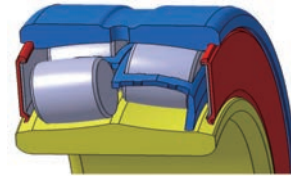

These bearings are shipped packed with grease

[Rotation torque test results]

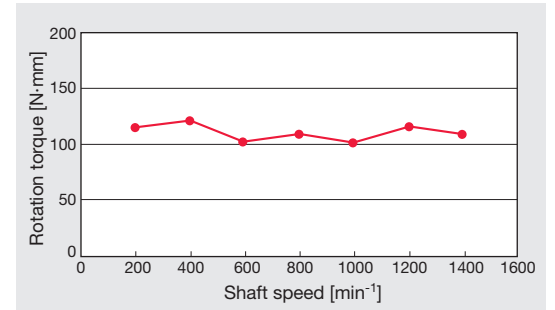

Refer to the size charts (p-29)

Plummer Blocks

Features

Manufactured and designed at NTN's exclusive casting plant in Japan to provide seamless integration

- ▶ Suitable for withstanding impact, vibrations, and heavy loads.
- ▶ Suitable for a broad operating temperature range (-20 to 300°C*).
- * This is the temperature range for the plummer block body. Special heat treatment is required for bearings.
- ▶ Selectable lubrication method (grease or oil).



Plummer block seal types



Rubber seal

Rubber seals are mainly used for grease lubrication with a maximum shaft speed of 5-6 m/s /.

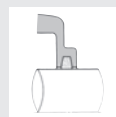

Felt seals

Felt seals and rubber seals are interchangeable. These can only be used with grease lubrication. Felt seals are not suitable for use in high dust, humidity environments. The maximum shaft speed for felt seals is approximately 4 m/s.



S-shaped seals

S-shaped seals (synthetic rubber seals w/spring) have excellent sealing performance and are usable for grease and oil-based lubricants (plummer blocks have a special specification). The maximum shaft speed for S-shaped seals is 10-12 m/s. Caution is required regarding the surface finish and hardness of the shaft especially in the seal contact area.

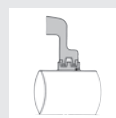

Labyrinth seals

Labyrinth rings are easy to install by O-ring attachment and are loosely fitted to flexibly follow the extension and contraction of the shaft (h9 shaft tolerance).

ULTAGE

ULTAGE Serise Spherical Roller Bearings

Long operating life, higher load capacities and enhanced high-speed operation provide maximum equipment productivity

▶ Type EA, Type EM

World's Highest Standard Load Capacity

By maximizing the roller diameter, the number of rollers and roller design, longer operating life and higher load ratings have been achieved. With this improvement maintenance cycles can be extended.

- ① **Basic Dynamic Load Rating : Up to 65% higher**
(compared to **NTN** conventional products)
- ② **Basic Static Load Rating : Up to 35% higher**
(compared to **NTN** conventional products)
- ③ **Operating Life : Up to 5 times longer**
(compared to **NTN** conventional products)

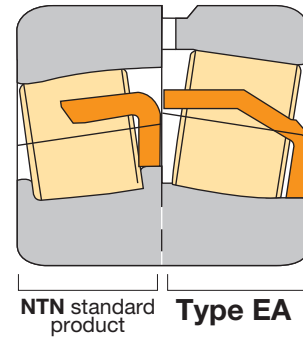

● Comparison of other manufacturer's cataloged basic dynamic load rating values (C_r)
22216 (ø80 × ø140 × 33)

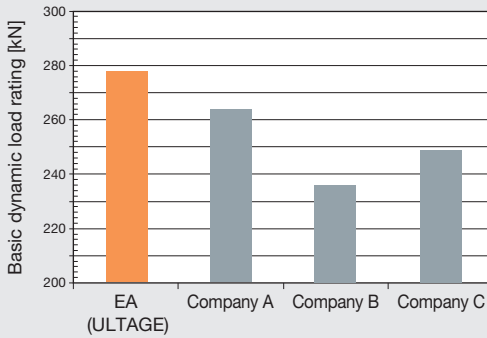

● Comparison of other manufacturer's cataloged basic static load rating values (C_{or})
22216 (ø80 × ø140 × 33)

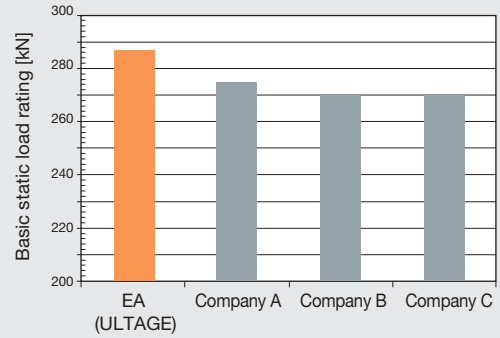

World's Highest Standard Maximum Shaft Speed

Higher operating speeds have been achieved by using an optimized design pressed steel cage.

Limiting speed : Up to a 20% increase when compared to NTN conventional products

The results of comparative bearing temperature rise testing under circulating oil conditions shows that this bearing reduces temperature rise at a lower torque compared to other manufacturer's bearings.

● Comparison of other manufacturer's cataloged shaft speeds
22216 (ø80 × ø140 × 33)

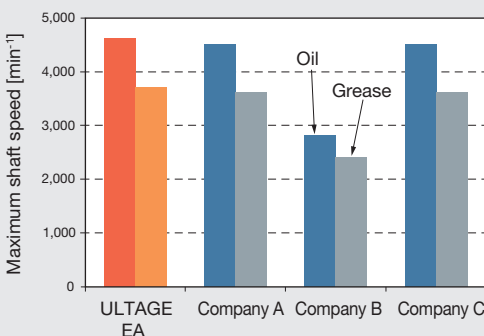

● Temperature rise test results (circulating oiling)
22216 (ø80 × ø140 × 33)

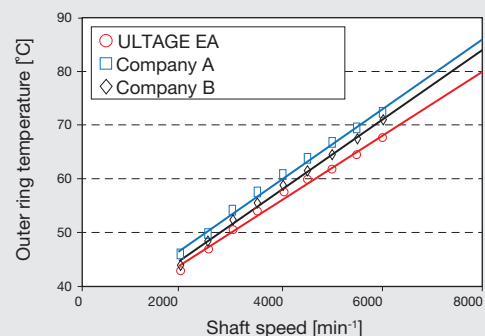



Enhanced Loads : Smaller Bearing

Due to higher load capacity a smaller, lighter weight bearing is used to achieve a longer life.

Part Number	Basic Load Rating		Basic Dimensions mm	Weight kg	Life Ratio
	Basic Dynamic Load Rating	Basic Static Load Rating			
22220B	315	415	ø100 × ø180 × 46	4.95	1
22217EA	324	330	ø85 × ø150 × 36	2.59	1.1
			△ 20%	△ 48%	10%

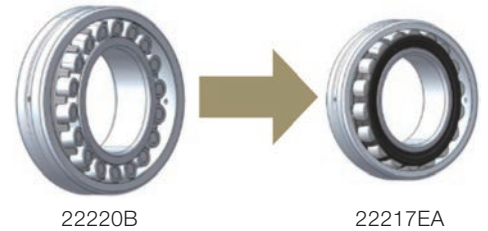

Overall size reduction up to **20%**

Weight ratio reduced by **48%**

Calculated operating life increased by **10%**

Outer Ring Oil Groove/Holes Standard

ULTAGE bearings are equipped with oil groove/holes as a standard feature. D1 is Japan specification, W33 is Europe specification. (22205, 22206, and 22207 support W33 specification)

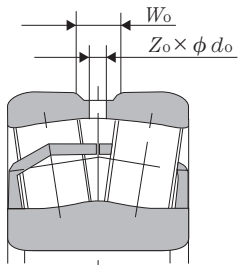

Bearing Outside Diameter mm		Number of Oil Holes	
Including	Less Than	D1	W33
		Z _o	Z _o
—	320	4	3
320	420 ¹⁾	8	3

1) 420 mm is included in this size class.



Bearing outer ring shape

W_o and d_o differ according to the model number. Refer to the catalog bearing size charts.

! Do not use the oil holes as position locating holes.

Improved Easy Handling

Assembly, disassembly, and re-lubrication have been improved due to the optimized pressed steel cage design.



Minimized roller projection enables quick and easy disassembly, repair and reassembly.



Grease dispersion to rolling surfaces is enhanced.

[Allowable Misalignment] ● 0.06 Cr < dynamic equivalent radial load : 0.009 rad (0.5°)
● Dynamic equivalent radial load ≤ 0.06 Cr : 0.035 rad (0.2°)

* If the installed misalignment is greater than recommended, there is a risk of roller/cage protrusion and impact to surrounding components.

RustGuard Corrosion-Resistant Bearings



Rust problems emerge during equipment shut downs when rolls are stationary in the wet environments of the Wire Section and Press Section.
 ULTAGE bearings support stable production in addition to corrosion-resistant performance.

Typical Failure Mechanism

Rust caused by leaving bearings in water-saturated environments

Flaking starts to occur in rusted areas



Downtime caused rust



Flaking



Typical Examples

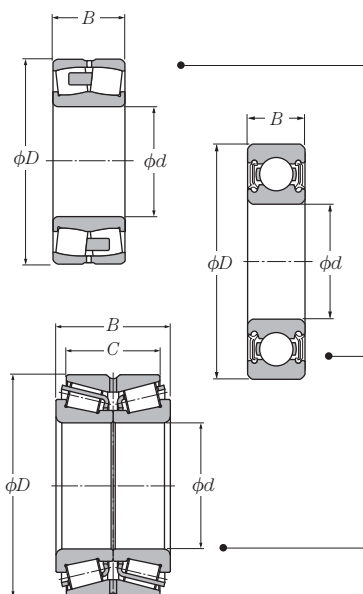

Service	Part Number	Basic Dimensions				Basic Dynamic Load Rating	Basic Static Load Rating
		mm					
		<i>d</i>	<i>D</i>	<i>B</i>	<i>C</i>	<i>C_r</i>	<i>C_{or}</i>
Press rolls	MX2-22210EM	50	90	23	–	125	117
Wire rolls	MX2-22318EMK	90	190	64	–	668	652
Wire rolls	MX2-23234EMK	170	310	110	–	1 700	2 070
Wire rolls	MX2-6TS3-6E-22336EMK	180	380	126	–	2 420	2 810
Press rolls	MX2-22320EMK	100	215	73	–	827	844
Suction press rolls	MX2-23056EM	280	420	106	–	2 170	3 150
Suction press rolls	MX2-230/850BL1K	850	1 220	272	–	9 750	22 700
Wire rolls	MX-6314T2LLU	70	150	35	–	104	68
Wire rolls	MX50-4T-NA558/552D	60.325	123.825	79.375	63.500	158	216
Wire rolls	MX50-4T-NA759/752D	88.900	161.925	104.775	85.725	270	385

Features

● Impact on operating life



Special phosphate coating treatment does not reduce the operating life.

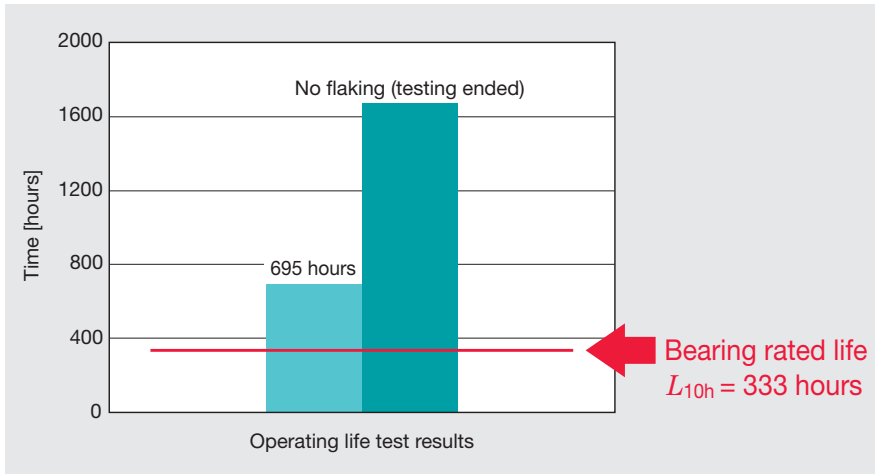

Unique coating treatment technology eliminates impact on operating life

[Test conditions]
 Bearing : #22318 (Number of rolling elements halved)
 Load : $F_r = 88.3 \text{ kN}$
 Shaft speed : $n = 2500 \text{ min}^{-1}$
 Lubrication : circulating oil VG220, 2 ℓ / min

● Improved corrosion resistance

After a corrosion-resistance performance comparison between untreated rollers (new) and coated rollers (after the operating test), the rust results on the wet surfaces shows that the coated rollers possess corrosion resistance even after the operating test.

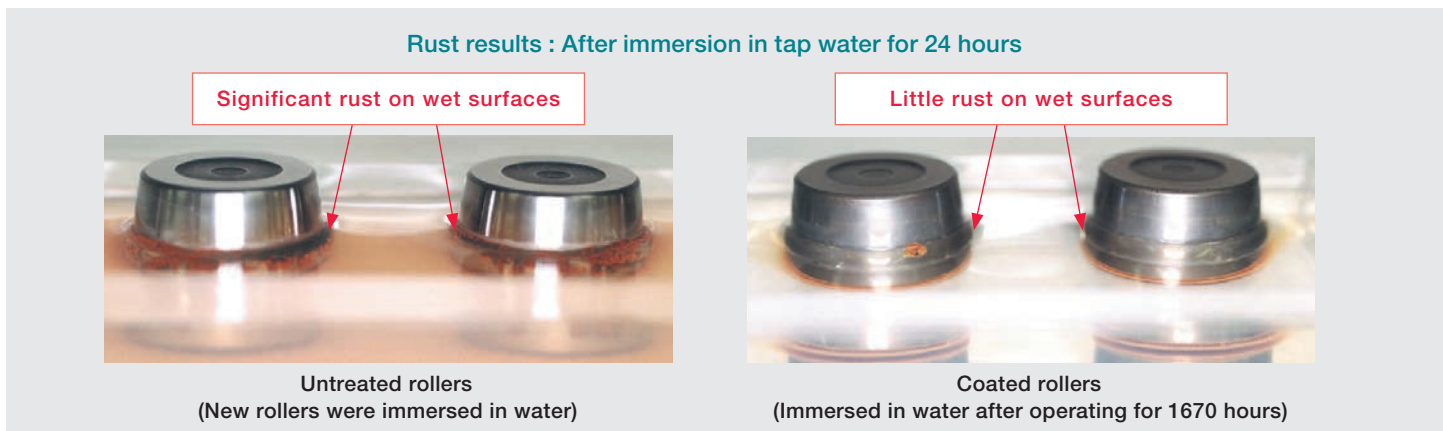

● Applicable with various bearing types

Can be applied to all types of bearings, such as spherical roller bearing, tapered roller bearing, etc. Furthermore, it is also suitable for all types of materials, such as bearing steels and case-hardened steels (below : carburized steels).



Long Operating Life EA Bearings



Case-hardened steel has been specially heat treated by composite carburizing and nitriding heat treatment. Therefore, the critical bearing surfaces have been strengthened against surface damage to achieve a dramatic increase in operating life.

Typical Failure Mechanism

Significant fit stress is caused by entry of foreign material and sudden temperature rise.



Inner ring breakage

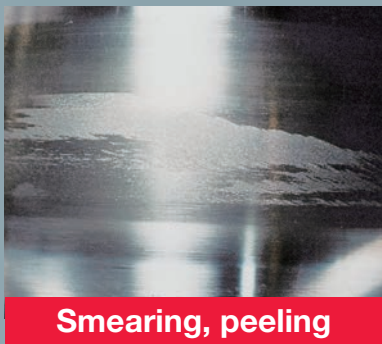

Smearing, peeling

Poor lubrication



Typical Examples

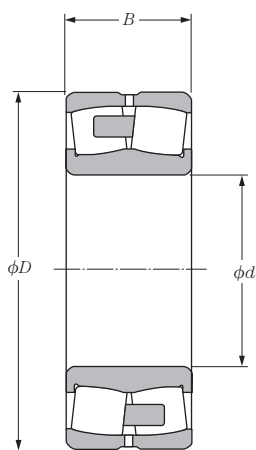

Service	Part Number	Basic Dimensions			Basic Dynamic Load Rating C_r	Basic Static Load Rating C_{or}
		mm				
		d	D	B	kN	
Dryer Section	TS3-EA3-22244EMK	220	400	108	2 210	2 690
	TS3-EA3-22322EM	110	240	80	975	972
	TS3-EA3-22324EM	120	260	86	1 170	1 280
	TS3-EA-23032EMK	160	240	60	748	1 000
	TS3-EA-23034EMK	170	260	67	914	1 240
	TS3-EA-23038EMK	190	290	75	1 140	1 570
	TS3-EA-23040EMK	200	310	82	1 310	1 790
	TS3-EA3-23144EMK	220	370	120	2 190	2 940
	TS3-EA3-23148EMK	240	400	128	2 510	3 500
	TS3-EA-23238EMK	190	340	120	1 990	2 480

Features

Operating life improvement for lubricant contaminated by foreign material : **5 times**
 (Compared to NTN's standard carburized steel bearings)

● Improved bearing strength

Material and fitting stress strength has been improved by combining nitrogen during the proper heat treatment conditions.

▶ Operating life for lubricant contaminated by foreign material

Figure 1 shows the results of the operating life comparison test for small tapered roller bearings using lubricant contaminated by foreign material. EA bearings show an operating life over 5 times longer than standard carburized steel bearings.

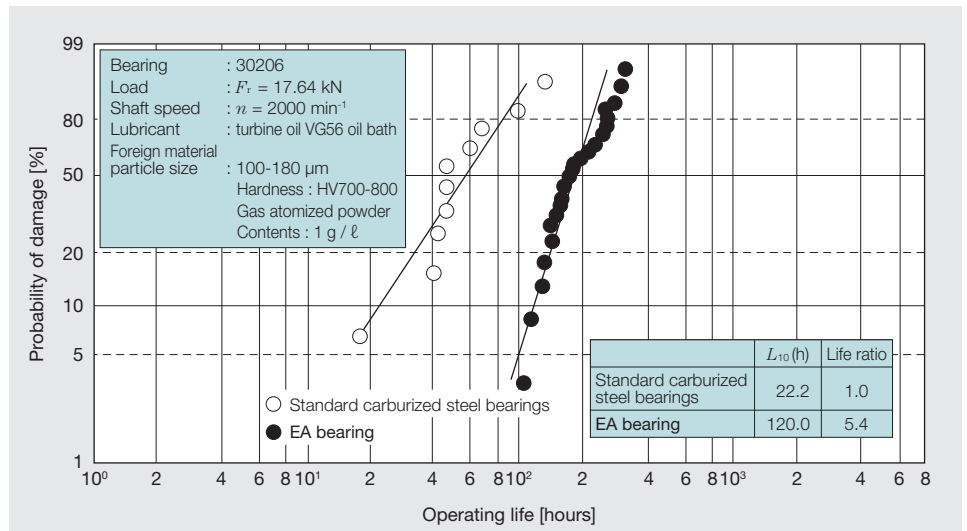

Figure 1. Test results of operating life for lubricant contaminated by foreign material

▶ Fatigue strength

Fatigue cracking causes catastrophic bearing failure. Although this form of damage is anticipated under harsh operating conditions, EA bearings possess a superior fatigue operating life above standard carburized steel bearings as shown in ring rotating fatigue strength testing and rolling fatigue strength testing by applying a large fitting stress, as shown in tables 1 and 2 respectively.

Fatigue cracking life improvement : **1.5 times**
 (Compared to NTN's standard carburized steel bearings)

Table 1. Test results of ring rotating fatigue strength

Bearings	L_{10} (Hours) $\times 10^4$ Cycles	L_{10} Ratio
Standard carburized steel bearings	6 670	1
EA bearing	9 020	1.4

[Test conditions]

Test equipment : NTN ring rotating fatigue strength test equipment
 Load : 9.8 kN
 Load speed : 8,000 cpm

Table 2. Test results of rolling fatigue strength using a large fitting stress

Bearings	L_{10} (Hours) $\times 10^4$ Cycles	L_{10} Ratio
Standard carburized steel bearings	2 030	1
EA bearing	6 240	3.1

[Test conditions]

Test equipment : NTN line contact type rolling operating life test equipment
 Fit stress : 425 MPa applied to rolling surfaces
 Load : 4.9 kN
 Load speed : 6120 cpm

Operating life under high fitting stress is **3 times longer**
 (Compared to NTN's standard carburized steel bearings)

Solid Grease Bearings

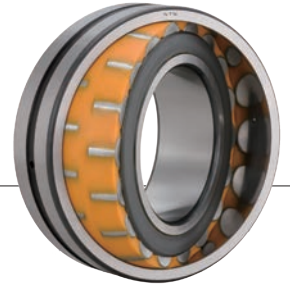

Lubricant leakage control is maximized using a solid lubricant composed of lubricating grease and polyethylene.
 Long-term use is made possible by continuous lubrication during equipment operation.

▶ Spot-pack



Deep groove ball bearings are equipped with spot-pack as standard

▶ Full-pack



Spherical roller bearings are full-pack as standard

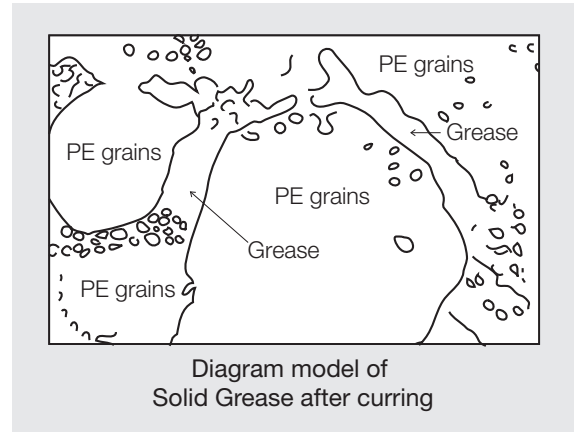

Typical Failure Mechanism

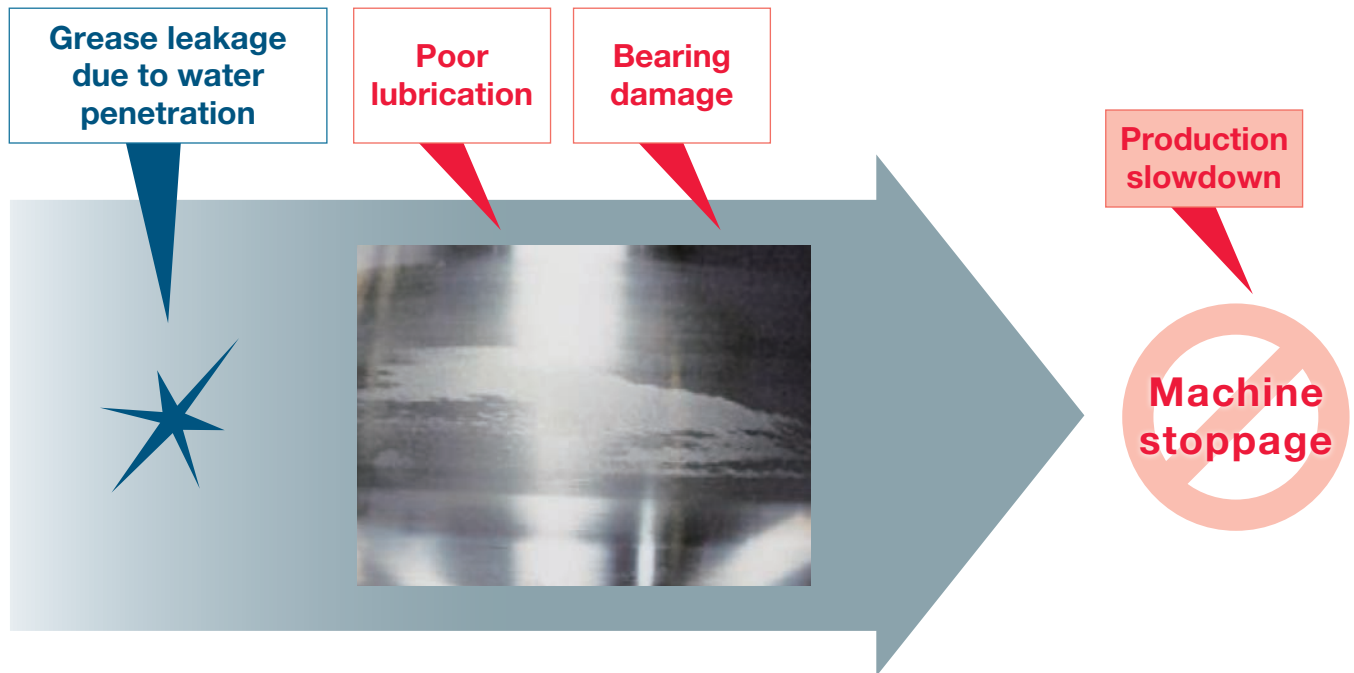

Features

● Minimal lubricant leakage

Lubricant is fed steadily onto the rotating surfaces by the heat and centrifugal force of the bearings. Minimal lubricant leakage prevents contamination of the surrounding area.

● Resistant to emulsification

Solid Grease is resistant to leaking even when bearings are subjected to large vibration and centrifugal force. The grease is less prone to emulsification even if there is water penetration, exhibiting superior lubrication characteristics compared to general-purpose greases.

Bearing Specifications

● Main ingredients and permissible operating temperature range

Solid Grease (product code)	Resin	Lubricant	Permissible Operating Temperature Range
General-purpose Solid Grease (LP03)	Ultra high molecular weight polyethylene	Li-mineral oil grease	-20~80°C (-4~194°F) max. 60°C (140°F) at regular operation conditions

● Production range

Solid Grease bearing for general use (LP03)

○: Standard type △: Special type ×: Not available

Bearing Designs	Lubricant Packing Method		Bearing Sizes (Bearing Outside Diameter Dimensions)
	Spot-pack	Full-pack	
Deep groove ball bearings	○●	△	Up to 350 mm diameter
Miniature/small dia. ball bearings	○●	×	(Bearing inside diameter : 6 to 9 mm)
Self-aligning ball bearings	×	○●	Up to 250 mm diameter
Spherical roller bearings	×	○●	Up to 250 mm diameter
Bearing units	○●	△	Up to 300 mm diameter
Needle roller bearings	×	○●	●

● Deep groove ball bearings are equipped with spot-pack and ZZ shields as standard. Certain bearing configurations and model numbers listed as standard specification are not available. Contact **NTN** for further information.

● Dimensions of the needle roller bearings differ for each bearing configuration. Contact **NTN** for further information.

Note : Standard bearings are not manufactured from corrosion resistant materials. However, stainless steel bearings are available.



● Minimum required load

In case of full-pack, in order for the rolling elements to rotate without sliding, at least approximately 1% of the basic dynamic load rating is required. Contact **NTN** for more information.

Typical examples of Solid Grease bearings for pulp mill bleach plant

Part Number	Basic Dimensions			Basic Dynamic Load Rating <i>C_r</i>	Basic Static Load Rating <i>C_{0r}</i>
	<i>d</i>	<i>D</i>	<i>B</i>		
22209EAKD1/LP03	45	85	23	121	113
22216EAKD1/LP03	80	140	23	278	287

Remark : Items marked 'K' indicate bearings with a bore taper ratio of 1/12.

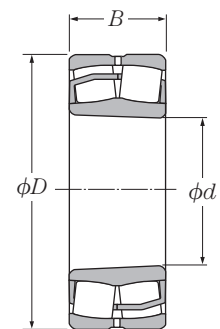

Tapered Bore (Type EA)

MEGAOHM™ Insulated Bearings

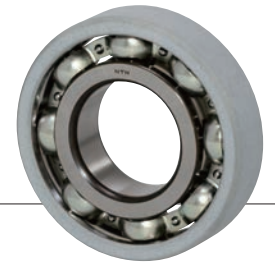

Electrolytic erosion caused by electric current leakage may occur in bearings used in electrical machinery, such as motors and generators, etc., which shortens the operating life of the bearings. NTN's MEGAOHM™ insulated bearings have been developed to prevent electrolytic erosion. These bearings are available in ceramic or resin types and can be selected to match the application. MEGAOHM™ insulated bearings possess the following excellent features.

Features

- Has insulation properties of 100 MΩ or higher when 500 VDC is applied.
 - Interchangeable with ISO 492, DIN 620, and JIS 1514 standard type bearings.
 - Choose from a broad lineup of insulating materials to match the application requirements for withstanding voltage and impact resistance, etc.
 - Compatible with bearings of inner diameter sizes of 50 to 160 mm.
- * Certain bearing configurations and model numbers among the bearing sizes are not available. Contact NTN for further information.

Typical Failure Mechanism



Construction

▶ Ceramic insulated bearings

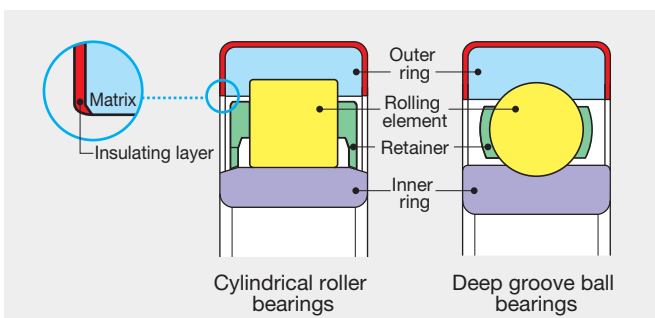

▶ Resin insulated bearings

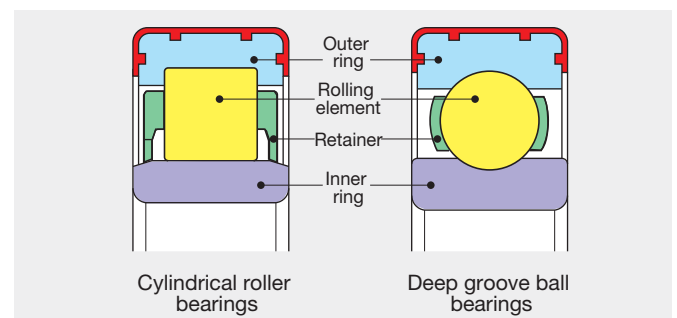

Operating caution : This bearing has an insulating effect and requires appropriate lubrication conditions. Check the conditions and location of use. Contact NTN for technical support.

Triple-Lip Sealed Bearings for Bearing Units

Bearings with excellent dust and water-resistant triple-lip seals achieve a longer operating life in dusty and wet environments.



Features

- The excellent dust and water-resistance ability extends the bearing replacement cycle, so maintenance costs are reduced.
- Bearing unit covers, which are typically required, are no longer needed, reducing the size of the bearings.
- Triple-lip seals are suitable for UC configuration bearings, so they are not only usable with the lubricating method but also compatible with the inserts in standard bearing units. Therefore, repair and replacement is easily accommodated.

Construction

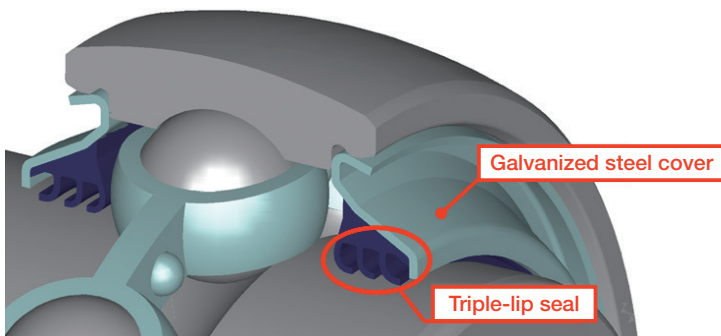

▶ Water-resistance performance test results

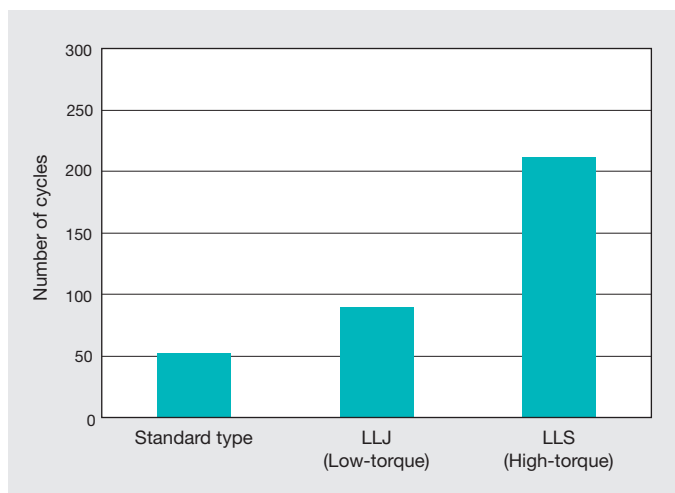

[Test conditions]

Test bearing	: UC205D1 Standard type, LLJ (low-torque type), LLS (high-torque type)
Shaft speed	: 800 min ⁻¹
Load	: None (belt tension only)
Test mode	: Intermittent operation (6 hours run / 6 hours stop = 1 cycle)
Test equipment	: NTN muddy water test equipment
Muddy water specification	: JIS Z8901 Kanto Loam Class 8
Dust to water mixture ratio	: 1:10 (ratio by weight)
Quantity of muddy water	: 1/4 to 1/3 of outer ring immersed
Testing termination conditions	: Muddy water leakage from bearing, bearing seizure, 0.6 G vibration when operating

Refer to the size charts (p-31)

ULTAGE

ULTAGE Series

Thrust Spherical Roller Bearings



Shaft washer

- Optimal curvature

Cage

- Window-type pressed steel cage

Housing washer

- Optimal curvature

Roller

- Larger rollers
- Maximum number of rollers

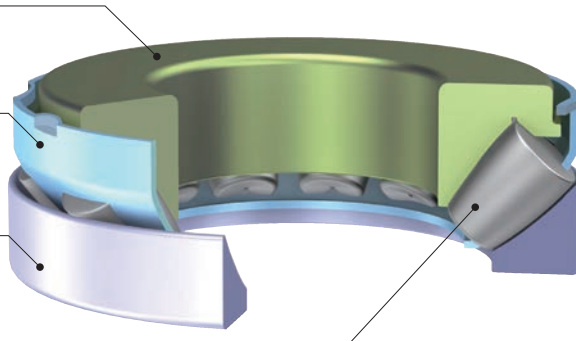

Long operating life

- World's highest standard high-load capacity
- Extended maintenance cycle
- Heat resistant to 200°C

Enhanced high-speed performance

- World's highest standard maximum shaft speed
- Simple pressed steel pocket-type cage

Improved handling

- Easy to lubricate design
- Compatible with oil or grease lubrication

Features

● World's highest standard high-load capacity

Long operating life with high-load capacity has been achieved by maximizing the size and number of rollers.

Basic dynamic load rating : **Up to 70% higher** (compared to NTN conventional products)

Operating life : **Up to 6 times longer** (compared to NTN conventional products)

● World's highest standard maximum shaft speed

High shaft speed has been achieved by using a new pressed steel cage.

Up to **20% higher** (compared to NTN conventional products)

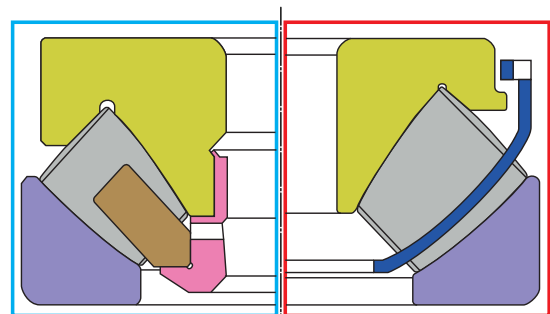

NTN conventional product

ULTAGE

● Specifications for pressed steel pocket-type cage

Usage with lubrication by oil and grease has been made possible by using a simplified pressed steel cage-type cage, expanding the usage range.

● Heat resistant up to 200°C

Using a special heat treatment as standard, excellent dimensional stability in high-temperature applications yields a longer operating life.

Allowable Misalignment

▶ 1 ~ 2°

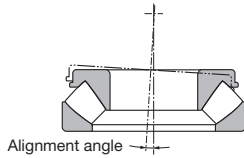

Maximum Shaft Speed

The maximum shaft speeds listed in the bearing size charts are reference values applicable to recommended bearing lubrication and cooling conditions.

The maximum shaft speeds listed in the catalogs are defined as follows.

▶ For oil lubrication

The shaft speed at which the temperature of the housing washer reaches 80°C when 1 liter / 0.25 gallons of VG32 spindle oil is supplied at ambient temperature viscosity, operating at 5% of the basic static load rating C_{0a} .

▶ For grease lubrication

The shaft speed at which the temperature of the housing washer reaches 80°C when the bearing space capacity is 100% packed with lithium grease (consistency : NLG13), running in has been completed, operating at 5% of the basic static load rating C_{0a} .

If the conditions of use (operating load, rotational speed pattern, lubrication condition, etc.) differ for either lubrication method, the temperature rise of the bearing will also differ. Therefore, select a bearing with a sufficient margin of permitted rotational speed, listed in the catalog. Furthermore, contact **NTN** if the bearing application will exceed 80% of the maximum shaft speed listed in the bearing size charts.

Performance Test Results

● Temperature rise test

(1) Vertical axis

[Test conditions]

Bearing model No. : 29418E
(ULTAGE thrust spherical roller bearing)
Axial load : 98 kN (5% C_{0a})
Shaft speed : 1000 to 2200 min⁻¹
Lubrication method : Oil lubrication
(circulating oiling)
Test equipment : Fig. 3

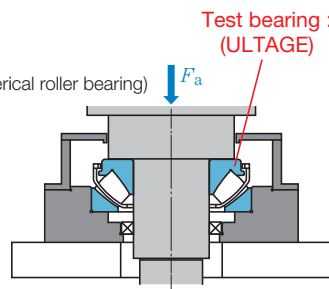
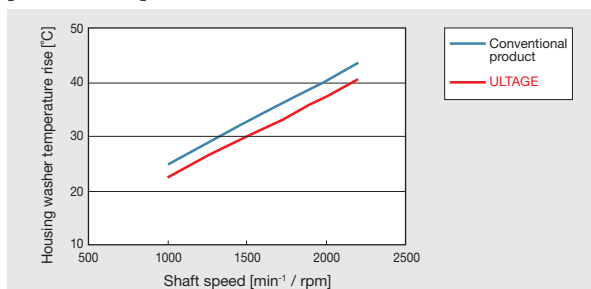

Fig. 3 : Test bearing arrangement

[Test results]



Allowable Radial Load

▶ $F_r / F_a \leq 0.55$

F_r : Radial load

F_a : Axial load

Lubrication Method

Thrust spherical roller bearings have areas in between the bearing rollers and raceway collar surface, etc., where it is more difficult for the lubricant to access. Therefore, ensure the bearings are supplied with sufficient lubrication. When using grease, pack the housing space with grease to ensure the static bearing spaces in the vertical and horizontal axes of the housing, shown in figures 1 and 2 respectively, are properly lubricated.

▶ Vertical axis

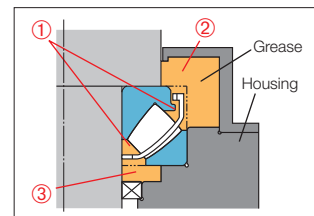

Bearing : Static space 100% packed
(Fig. 1-①)
Housing : Space 100%
(Fig. 1-②③)

Fig. 1 : Grease lubrication in the vertical axis

▶ Horizontal axis

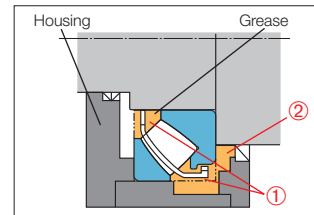

Bearing : Static space 100% packed
(Fig. 2-①)
Housing : Space on the side of the bearing washer 100% packed
(Fig. 2-②)

Fig. 2 : Grease lubrication in the horizontal axis

(2) Horizontal axis

[Test conditions]

Bearing model No. : 29418E
(ULTAGE thrust spherical roller bearing)
Axial load : 98 kN (5% C_{0a})
Shaft speed : $n = 1000$ to 2200 min⁻¹
Lubrication method : Oil lubrication
(circulating oiling)
Test equipment : Fig. 4

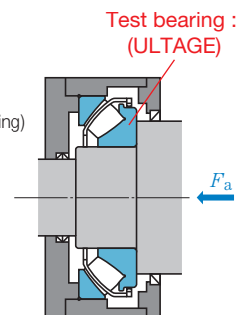
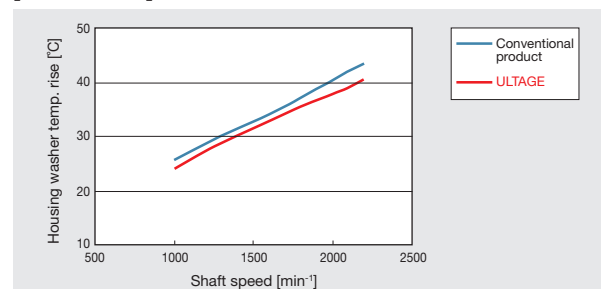

Fig. 4 : Test bearing arrangement

[Test results]



Refer to the size charts (p-33)

Constant Velocity Joints

Superior performance of constant velocity joints

- No lubrication required** Boot-sealed to enable operation for prolonged periods without lubricating.
- Low vibration/noise efficient rotation** They ensure high quality manufacturing due to their low vibration/noise and efficient rotation (constant velocity rotation) compared to other couplings.
- Ambient environment** They are boot-sealed. Therefore, there is no loss of grease and clean environments can be maintained.
- Easy handling** They are easy to handle because, unlike cross-joints, they require no left-right angle/phase matching or centering during installation.
- Safety** Constant velocity joints are covered by a boot. Therefore, they are safe to handle without risk of trapping fingers in cross-joint yokes.

These joints efficiently transfer rotational torque from an input (electric motor, etc.) to an output (roller, etc.) across a variety of angles and distances.

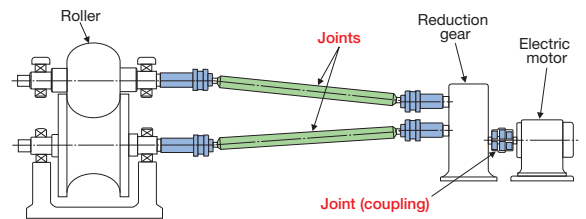

► BJ

● BJ disc type

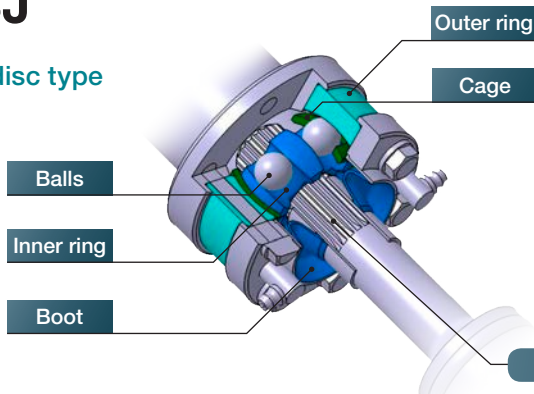

- Excellent high-speed rotation performance
- Max. permitted angle : 14-18°

● BJ cup type

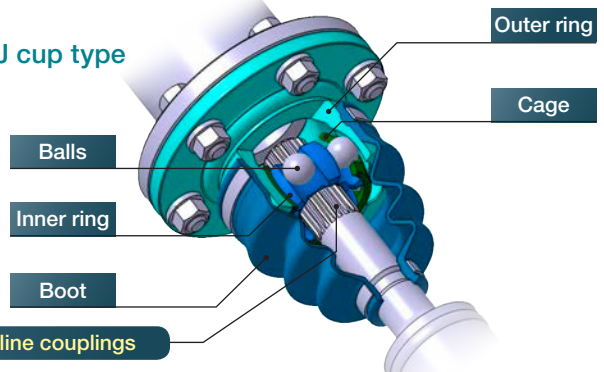

- Max. permitted angle : 25°
- Excellent seal performance

► DOJ/BC couplings

● DOJ



- Extendable inside the joint while under torque load
- Max. permitted angle : 68mm to 200mm size : 20°
225mm to 625mm size : 8° to 10°

● BC coupling

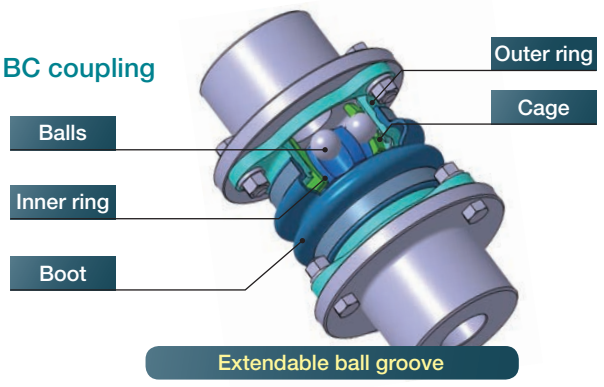

- No need to center/easy to install
- Max. permitted angle : 5°
- Extendable inside main body

Constant velocity joints are completely isokinetic without fluctuation in angular velocity

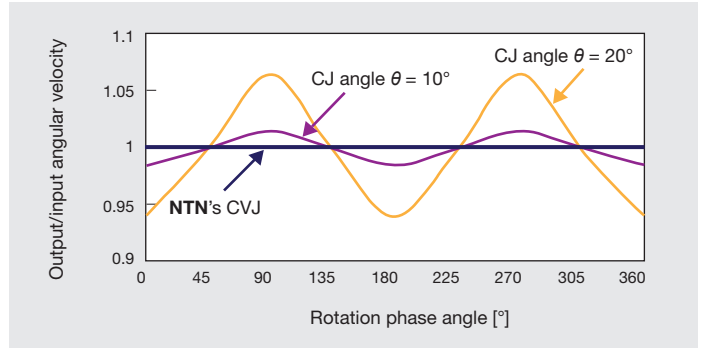
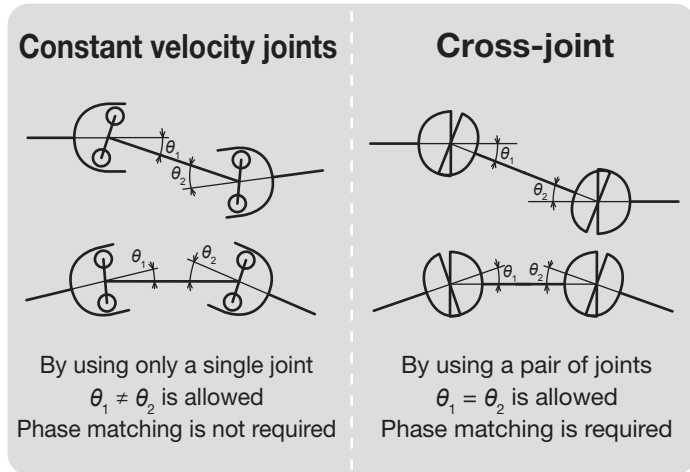

BC Coupling

BC couplings manufactured by **NTN** can be used in replacement of general couplings.❶

Take a closer look at the easy installation/removal characteristics, degree of angular deflection, and eccentricity that these BC couplings can easily cope with.

Chain Coupling

Gear Coupling

Disc Coupling

Rubber Coupling

By substituting with BC couplings... Replacement

No centering required
Improve work efficiency, reduce maintenance man-hours

No lubrication required
Boot-sealed to enable operation for prolonged periods without lubricating.

Absorb vibration

Comparison of coupling types (50 mm bore diameter comparison) ↓

Coupling Function	Chain Coupling	Gear Coupling	Disc Coupling	Rubber Coupling	NTN BC Couplings
Maximum angle of deflection (°)	1.0	1.5	1.0	0.3	5.0
Maximum degree of eccentricity (mm)	0.4	1.0	0.2	0.2	5.0
Maximum torque (N•m)	932	932	775	490	932
Maximum distance between shafts (mm)	12	8	12	3	103
Outside diameter (mm)	130	140	143	120	134
Weight (kg)	6.2	7.5	6.9	6.7	8.5
Independent installation and removal	Not possible	Not possible	Not possible	Not possible	Possible
Maintenance	Time required for centering				No centering or re-lubrication required

❶ Replacement may not be possible depending on conditions. Check the conditions and location of use. Contact **NTN** for technical support.

ULTAGE Series Spherical Roller Bearings [Type EA, Type EM]

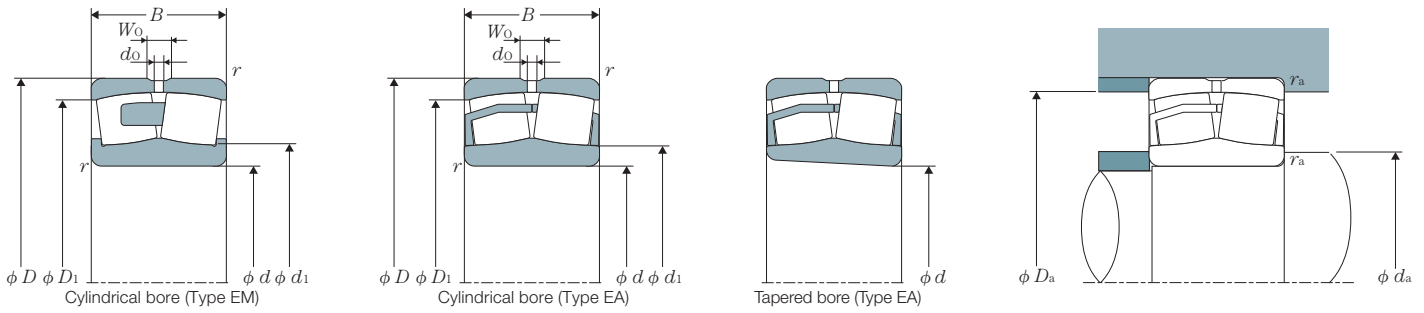

d	Basic Dimensions					Basic Dynamic Load Rating kN	Basic Static Load Rating kgf	Basic Dynamic Load Rating kgf	Basic Static Load Rating kgf	Permitted Rotational Speed			
	mm									min ⁻¹		Grease Lubrication	Oil Lubrication
	D	B	r _{s min} [Ⓜ]	W _o	d _o					Cr	Cor		
25	52	18	1	3	1.5	57.3	46.1	5 840	4 700	10 400	13 000		
	52	18	1	3	1.5	57.3	46.1	5 840	4 700	10 400	13 000		
30	62	20	1	4	2	75.7	64.5	7 720	6 580	8 800	11 000		
	62	20	1	4	2	75.7	64.5	7 720	6 580	8 800	11 000		
35	72	23	1.1	5	2	100	92	10 200	9 380	7 500	9 400		
	72	23	1.1	5	2	100	92	10 200	9 380	7 500	9 400		
40	80	23	1.1	5	2.5	116	105	11 800	10 700	6 800	8 500		
	80	23	1.1	5	2.5	110	98	11 200	10 000	6 800	8 500		
	90	33	1.5	6	3	169	152	17 200	15 500	5 400	6 600		
	90	33	1.5	6	3	169	152	17 200	15 500	5 400	6 600		
45	85	23	1.1	6	2.5	121	113	12 300	11 500	6 100	7 700		
	85	23	1.1	6	2.5	116	106	11 800	10 800	6 100	7 700		
	100	36	1.5	6	3	206	187	21 000	19 100	4 600	5 700		
	100	36	1.5	6	3	206	187	21 000	19 100	4 600	5 700		
50	90	23	1.1	6	2.5	130	124	13 300	12 600	5 700	7 200		
	90	23	1.1	6	2.5	125	117	12 700	11 900	5 700	7 200		
	110	40	2	7	3.5	250	232	25 400	23 700	4 300	5 300		
	110	40	2	7	3.5	250	232	25 400	23 700	4 300	5 300		
55	100	25	1.5	6	3	155	148	15 800	15 100	5 300	6 700		
	100	25	1.5	6	3	148	140	15 100	14 300	5 300	6 700		
	120	43	2	8	3.5	296	274	30 200	28 000	3 900	4 800		
	120	43	2	8	3.5	296	274	30 200	28 000	3 900	4 800		
60	110	28	1.5	7	3	187	181	19 100	18 400	4 800	6 000		
	110	28	1.5	7	3	179	171	18 300	17 400	4 800	6 000		
	130	46	2.1	9	4	340	319	34 700	32 600	3 600	4 600		
	130	46	2.1	9	4	340	319	34 700	32 600	3 600	4 600		
65	120	31	1.5	8	3.5	226	224	23 100	22 900	4 400	5 500		
	120	31	1.5	8	3.5	217	212	22 100	21 600	4 400	5 500		
	140	48	2.1	9	4	369	343	37 600	35 000	3 300	4 100		
	140	48	2.1	9	4	369	343	37 600	35 000	3 300	4 100		
70	125	31	1.5	7	3.5	235	240	24 000	24 400	4 100	5 200		
	125	31	1.5	7	3.5	235	240	24 000	24 400	4 100	5 200		
	150	51	2.1	10	5	420	396	42 800	40 400	3 000	3 800		
	150	51	2.1	10	5	420	396	42 800	40 400	3 000	3 800		
75	130	31	1.5	7	3.5	244	249	24 800	25 400	4 000	5 000		
	130	31	1.5	7	3.5	244	249	24 800	25 400	4 000	5 000		
	160	55	2.1	10	5	491	467	50 100	47 600	2 900	3 600		
	160	55	2.1	10	5	491	467	50 100	47 600	2 900	3 600		
80	140	33	2	8	3.5	278	287	28 400	29 300	3 700	4 600		
	140	33	2	8	3.5	267	272	27 300	27 700	3 700	4 600		
	170	58	2.1	10	5	541	522	55 200	53 200	2 700	3 400		
	170	58	2.1	10	5	541	522	55 200	53 200	2 700	3 400		
85	150	36	2	8	3.5	324	330	33 000	33 600	3 400	4 300		
	150	36	2	8	3.5	324	330	33 000	33 600	3 400	4 300		
	180	60	3	11	5	599	604	61 100	61 600	2 600	3 200		
	180	60	3	11	5	599	604	61 100	61 600	2 600	3 200		

① Items marked 'K' indicate bearings with a bore taper ratio of 1/12. ② Indicates the minimum allowed chamfer dimension γ*.

Dynamic equivalent radial load

$$P_r = XF_r + YF_a$$

$\frac{F_a}{F_r} \leq e$		$\frac{F_a}{F_r} > e$	
X	Y	X	Y
1	Y ₁	0.67	Y ₂

Static equivalent radial load

$$P_{0r} = F_r + Y_0 F_a$$

e, *Y*₁, *Y*₂ and *Y*₀ are obtained from the tables below.

Bearing Number

222 16 EA K D1 C3

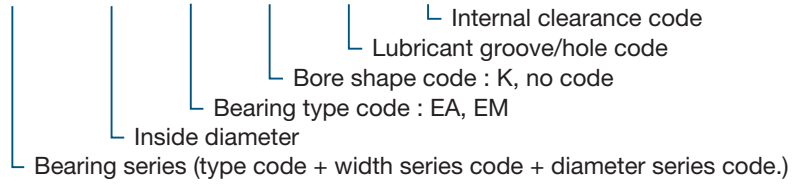

Part Number		Installation Dimensions					Constant	Axial Load Coefficient			Weight (Ref.)	
Cylindrical Bore	Tapered Bore [®]	<i>d</i> ₁	<i>d</i> _{a min}	<i>D</i> _{a max}	<i>D</i> ₁	<i>r</i> _{as max}	<i>e</i>	<i>Y</i> ₁	<i>Y</i> ₂	<i>Y</i> ₀	kg Cylindrical Bore	Tapered Bore
22205EAW33	22205EAKW33	30	30	46	46	1	0.34	2.00	2.98	1.96	0.173	0.169
22205EMW33	22205EMKW33	30	30	46	46	1	0.34	2.00	2.98	1.96	0.174	0.171
22206EAW33	22206EAKW33	37	36	56	55	1	0.31	2.15	3.20	2.10	0.278	0.272
22206EMW33	22206EMKW33	37	36	56	55	1	0.31	2.15	3.20	2.10	0.281	0.275
22207EAW33	22207EAKW33	45	42	65	63	1.1	0.31	2.21	3.29	2.16	0.438	0.430
22207EMW33	22207EMKW33	45	42	65	63	1.1	0.31	2.21	3.29	2.16	0.442	0.433
22208EAD1	22208EAKD1	50	47	73	71	1.1	0.27	2.47	3.67	2.41	0.528	0.518
22208EMD1	22208EMKD1	50	47	73	71	1.1	0.27	2.47	3.67	2.41	0.529	0.519
22308EAD1	22308EAKD1	52	49	81	78	1.5	0.36	1.87	2.79	1.83	1.02	1.00
22308EMD1	22308EMKD1	52	49	81	78	1.5	0.36	1.87	2.79	1.83	1.03	1.01
22209EAD1	22209EAKD1	54	52	78	76	1.1	0.26	2.64	3.93	2.58	0.572	0.561
22209EMD1	22209EMKD1	54	52	78	76	1.1	0.26	2.64	3.93	2.58	0.577	0.566
22309EAD1	22309EAKD1	58	54	91	87	1.5	0.36	1.90	2.83	1.86	1.37	1.34
22309EMD1	22309EMKD1	58	54	91	87	1.5	0.36	1.90	2.83	1.86	1.38	1.35
22210EAD1	22210EAKD1	59	57	83	81	1.1	0.24	2.84	4.23	2.78	0.614	0.602
22210EMD1	22210EMKD1	59	57	83	81	1.1	0.24	2.84	4.23	2.78	0.616	0.604
22310EAD1	22310EAKD1	63	61	99	95	2	0.36	1.87	2.79	1.83	1.82	1.79
22310EMD1	22310EMKD1	63	61	99	95	2	0.36	1.87	2.79	1.83	1.84	1.80
22211EAD1	22211EAKD1	66	64	91	90	1.5	0.23	2.95	4.40	2.89	0.830	0.814
22211EMD1	22211EMKD1	66	64	91	90	1.5	0.23	2.95	4.40	2.89	0.827	0.811
22311EAD1	22311EAKD1	68	66	109	104	2	0.36	1.87	2.79	1.83	2.31	2.26
22311EMD1	22311EMKD1	68	66	109	104	2	0.36	1.87	2.79	1.83	2.34	2.29
22212EAD1	22212EAKD1	71	69	101	99	1.5	0.24	2.84	4.23	2.78	1.14	1.12
22212EMD1	22212EMKD1	71	69	101	99	1.5	0.24	2.84	4.23	2.78	1.15	1.13
22312EAD1	22312EAKD1	75	72	118	113	2.1	0.35	1.95	2.90	1.91	2.86	2.80
22312EMD1	22312EMKD1	75	72	118	113	2.1	0.35	1.95	2.90	1.91	2.91	2.85
22213EAD1	22213EAKD1	78	74	111	107	1.5	0.24	2.79	4.15	2.73	1.52	1.49
22213EMD1	22213EMKD1	78	74	111	107	1.5	0.24	2.79	4.15	2.73	1.53	1.50
22313EAD1	22313EAKD1	81	77	128	122	2.1	0.33	2.06	3.06	2.01	3.48	3.41
22313EMD1	22313EMKD1	81	77	128	122	2.1	0.33	2.06	3.06	2.01	3.50	3.43
22214EAD1	22214EAKD1	84	79	116	113	1.5	0.22	3.01	4.48	2.94	1.61	1.58
22214EMD1	22214EMKD1	84	79	116	113	1.5	0.22	3.01	4.48	2.94	1.64	1.60
22314EAD1	22314EAKD1	85	82	138	131	2.1	0.34	2.00	2.98	1.96	4.25	4.16
22314EMD1	22314EMKD1	85	82	138	131	2.1	0.34	2.00	2.98	1.96	4.31	4.22
22215EAD1	22215EAKD1	88	84	121	118	1.5	0.22	3.14	4.67	3.07	1.67	1.64
22215EMD1	22215EMKD1	88	84	121	118	1.5	0.22	3.14	4.67	3.07	1.71	1.67
22315EAD1	22315EAKD1	91	87	148	139	2.1	0.34	2.00	2.98	1.96	5.18	5.07
22315EMD1	22315EMKD1	91	87	148	139	2.1	0.34	2.00	2.98	1.96	5.27	5.16
22216EAD1	22216EAKD1	94	91	129	127	2	0.22	3.14	4.67	3.07	2.09	2.05
22216EMD1	22216EMKD1	94	91	129	127	2	0.22	3.14	4.67	3.07	2.11	2.07
22316EAD1	22316EAKD1	98	92	158	148	2.1	0.34	2.00	2.98	1.96	6.12	5.99
22316EMD1	22316EMKD1	98	92	158	148	2.1	0.34	2.00	2.98	1.96	6.28	6.15
22217EAD1	22217EAKD1	100	96	139	137	2	0.22	3.07	4.57	3.00	2.59	2.54
22217EMD1	22217EMKD1	100	96	139	137	2	0.22	3.07	4.57	3.00	2.67	2.62
22317EAD1	22317EAKD1	107	99	166	157	3	0.32	2.09	3.11	2.04	7.18	7.04
22317EMD1	22317EMKD1	107	99	166	157	3	0.32	2.09	3.11	2.04	7.29	7.15

ULTAGE Series Spherical Roller Bearings [Type EA, Type EM]

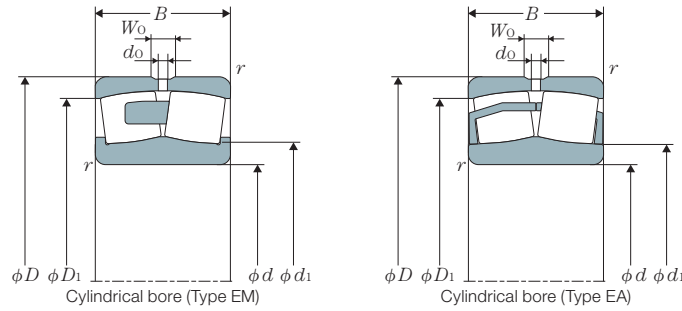

d	Basic Dimensions					Basic Dynamic Load Rating	Basic Static Load Rating	Basic Dynamic Load Rating	Basic Static Load Rating	Permitted Rotational Speed	
	mm					kN		kgf		min ⁻¹	
	D	B	r _{s min} ^②	Wo	do	Cr	Cor	Cr	Cor	Grease Lubrication	Oil Lubrication
90	160	40	2	10	4.5	384	398	39 200	40 600	3 200	4 000
	160	40	2	10	4.5	384	398	39 200	40 600	3 200	4 000
	160	52.4	2	9	4	467	513	47 700	52 300	2 600	3 200
	190	64	3	12	5	668	652	68 100	66 400	2 500	3 000
	190	64	3	12	5	668	652	68 100	66 400	2 500	3 000
95	170	43	2.1	10	4.5	416	417	42 400	42 600	3 000	3 800
	170	43	2.1	10	4.5	416	417	42 400	42 600	3 000	3 800
	200	67	3	12	6	732	751	74 600	76 500	2 300	2 800
	200	67	3	12	6	732	751	74 600	76 500	2 300	2 800
100	165	52	2	8	4	464	563	47 300	57 400	2 400	3 000
	165	52	2	8	4	480	590	49 000	60 100	2 400	3 000
	180	46	2.1	11	5	472	495	48 100	50 500	2 800	3 600
	180	46	2.1	11	5	472	495	48 100	50 500	2 800	3 600
	180	60.3	2.1	9	4.5	586	661	59 800	67 400	2 300	2 900
	215	73	3	13	6	827	844	84 300	86 100	2 100	2 600
110	170	45	2	8	3.5	417	517	42 500	52 700	2 600	3 300
	170	45	2	8	3.5	417	517	42 500	52 700	2 600	3 300
	180	56	2	9	4	547	669	55 800	68 200	2 200	2 800
	180	56	2	9	4	547	669	55 800	68 200	2 200	2 800
	180	69	2	8	4	622	769	63 400	78 400	2 200	2 700
	200	53	2.1	12	6	602	643	61 400	65 600	2 600	3 300
	200	53	2.1	12	6	602	643	61 400	65 600	2 600	3 300
	200	69.8	2.1	11	5	752	869	76 700	88 600	2 100	2 600
	240	80	3	16	7	975	972	99 500	99 100	2 000	2 400
120	180	46	2	8	3.5	446	577	45 500	58 900	2 400	3 100
	180	46	2	8	3.5	446	577	45 500	58 900	2 400	3 100
	180	60	2	8	3.5	526	726	53 700	74 100	2 100	2 600
	200	62	2	10	4.5	663	820	67 600	83 600	2 000	2 500
	200	62	2	10	4.5	663	820	67 600	83 600	2 000	2 500
	200	80	2	10	4.5	756	991	77 100	101 000	1 900	2 500
	215	58	2.1	12	6	688	753	70 100	76 800	2 400	3 000
	215	58	2.1	12	6	688	753	70 100	76 800	2 400	3 000
	215	76	2.1	11	5	857	998	87 300	102 000	1 900	2 400
	260	86	3	18	8	1 170	1 280	119 000	131 000	1 800	2 200
	260	86	3	18	8	1 170	1 280	119 000	131 000	1 800	2 200
130	200	52	2	9	4	565	721	57 600	73 500	2 200	2 900
	200	52	2	9	4	565	721	57 600	73 500	2 200	2 900
	200	69	2	9	4	682	936	69 600	95 400	1 900	2 400
	210	64	2	10	4.5	710	906	72 400	92 400	1 900	2 400
	210	64	2	10	4.5	710	906	72 400	92 400	1 900	2 400
	210	80	2	10	4.5	803	1 080	81 900	110 000	1 800	2 400
	230	64	3	13	6	808	898	82 400	91 600	2 200	2 800
	230	64	3	13	6	808	898	82 400	91 600	2 200	2 800
	230	80	3	12	5	958	1 130	97 700	115 000	1 700	2 300
	280	93	4	19	9	1 330	1 400	135 000	143 000	1 600	2 000
	280	93	4	19	9	1 330	1 400	135 000	143 000	1 600	2 000

① Items marked 'K' indicate bearings with a bore taper ratio of 1/12, and items marked 'K30' indicate bearings with a bore taper ratio of 1/30. ② Indicates the minimum allowed chamfer dimension r_s.

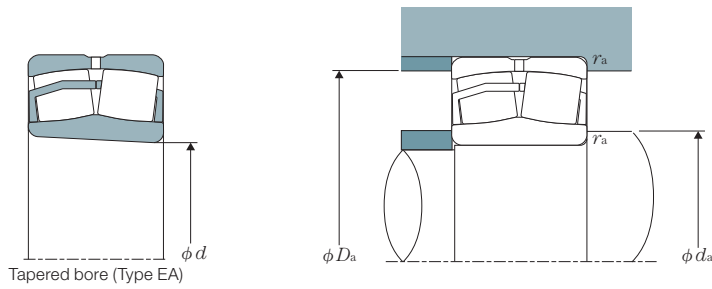

Dynamic equivalent radial load

$$P_r = XF_r + YF_a$$

$\frac{F_a}{F_r} \leq e$		$\frac{F_a}{F_r} > e$	
X	Y	X	Y
1	Y_1	0.67	Y_2

Static equivalent radial load

$$P_{or} = F_r + Y_0 F_a$$

e , Y_1 , Y_2 and Y_0 are obtained from the tables below.

Part Number		Installation Dimensions						Constant	Axial Load Coefficient			Weight (Ref.)	
Cylindrical Bore	Tapered Bore [®]	d_1	$d_{a \min}$	$D_{a \max}$	D_1	$r_{as \max}$	e		Y_1	Y_2	Y_0	kg Cylindrical Bore	Tapered Bore
22218EAD1	22218EAKD1	105	101	149	144	2	0.23	2.90	4.31	2.83	3.34	3.27	
22218EMD1	22218EMKD1	105	101	149	144	2	0.23	2.90	4.31	2.83	3.43	3.37	
23218EMD1	23218EMKD1	104	101	149	141	2	0.30	2.25	3.34	2.20	4.43	4.31	
22318EAD1	22318EAKD1	110	104	176	166	3	0.33	2.06	3.06	2.01	8.42	8.25	
22318EMD1	22318EMKD1	110	104	176	166	3	0.33	2.06	3.06	2.01	8.53	8.35	
22219EAD1	22219EAKD1	110	107	158	153	2.1	0.23	2.95	4.40	2.89	3.98	3.90	
22219EMD1	22219EMKD1	110	107	158	153	2.1	0.23	2.95	4.40	2.89	4.06	3.98	
22319EAD1	22319EAKD1	120	109	186	174	3	0.32	2.09	3.11	2.04	9.91	9.71	
22319EMD1	22319EMKD1	120	109	186	174	3	0.32	2.09	3.11	2.04	10.0	9.82	
23120EAD1	23120EAKD1	114	111	154	147	2	0.28	2.39	3.56	2.34	4.37	4.24	
23120EMD1	23120EMKD1	114	111	154	147	2	0.28	2.39	3.56	2.34	4.45	4.32	
22220EAD1	22220EAKD1	118	112	168	161	2.1	0.24	2.84	4.23	2.78	4.90	4.80	
22220EMD1	22220EMKD1	118	112	168	161	2.1	0.24	2.84	4.23	2.78	5.02	4.93	
23220EMD1	23220EMKD1	118	112	168	159	2.1	0.31	2.18	3.24	2.13	6.51	6.33	
22320EAD1	22320EAKD1	127	114	201	187	3	0.34	1.98	2.94	1.93	12.6	12.3	
22320EMD1	22320EMKD1	127	114	201	187	3	0.34	1.98	2.94	1.93	12.9	12.7	
23022EAD1	23022EAKD1	123	119	161	155	2	0.23	2.95	4.40	2.89	3.66	3.55	
23022EMD1	23022EMKD1	123	119	161	155	2	0.23	2.95	4.40	2.89	3.66	3.55	
23122EAD1	23122EAKD1	125	121	169	161	2	0.28	2.43	3.61	2.37	5.66	5.49	
23122EMD1	23122EMKD1	125	121	169	161	2	0.28	2.43	3.61	2.37	5.53	5.36	
24122EMD1	24122EMK30D1	121	121	169	158	2	0.36	1.90	2.83	1.86	6.75	6.65	
22222EAD1	22222EAKD1	130	122	188	179	2.1	0.25	2.69	4.00	2.63	7.10	6.95	
22222EMD1	22222EMKD1	130	122	188	179	2.1	0.25	2.69	4.00	2.63	7.30	7.15	
23222EMD1	23222EMKD1	130	122	188	176	2.1	0.32	2.12	3.15	2.07	9.41	9.14	
22322EAD1	22322EAKD1	139	124	226	209	3	0.32	2.09	3.11	2.04	17.0	16.6	
22322EMD1	22322EMKD1	139	124	226	209	3	0.32	2.09	3.11	2.04	17.4	17.1	
23024EAD1	23024EAKD1	134	129	171	165	2	0.22	3.14	4.67	3.07	4.02	3.90	
23024EMD1	23024EMKD1	134	129	171	165	2	0.22	3.14	4.67	3.07	4.02	3.90	
24024EMD1	24024EMK30D1	132	129	171	161	2	0.29	2.32	3.45	2.26	5.28	5.21	
23124EAD1	23124EAKD1	138	131	189	179	2	0.28	2.43	3.61	2.37	7.72	7.49	
23124EMD1	23124EMKD1	138	131	189	179	2	0.28	2.43	3.61	2.37	7.77	7.54	
24124EMD1	24124EMK30D1	136	131	189	173	2	0.37	1.84	2.74	1.80	10.0	9.87	
22224EAD1	22224EAKD1	141	132	203	193	2.1	0.25	2.74	4.08	2.68	8.88	8.68	
22224EMD1	22224EMKD1	141	132	203	193	2.1	0.25	2.74	4.08	2.68	9.01	8.82	
23224EMD1	23224EMKD1	139	132	203	190	2.1	0.32	2.09	3.11	2.04	11.7	11.3	
22324EAD1	22324EAKD1	156	134	246	225	3	0.32	2.09	3.11	2.04	22.3	21.9	
22324EMD1	22324EMKD1	156	134	246	225	3	0.32	2.09	3.11	2.04	22.7	22.2	
23026EAD1	23026EAKD1	145	139	191	183	2	0.22	3.01	4.48	2.94	5.88	5.71	
23026EMD1	23026EMKD1	145	139	191	183	2	0.22	3.01	4.48	2.94	5.90	5.73	
24026EMD1	24026EMK30D1	143	139	191	178	2	0.31	2.20	3.27	2.15	7.82	7.71	
23126EAD1	23126EAKD1	148	141	199	189	2	0.27	2.51	3.74	2.45	8.45	8.19	
23126EMD1	23126EMKD1	148	141	199	189	2	0.27	2.51	3.74	2.45	8.51	8.25	
24126EMD1	24126EMK30D1	146	141	199	183	2	0.34	1.96	2.92	1.92	10.7	10.5	
22226EAD1	22226EAKD1	151	144	216	206	3	0.25	2.69	4.00	2.63	11.0	10.7	
22226EMD1	22226EMKD1	151	144	216	206	3	0.25	2.69	4.00	2.63	11.1	10.9	
23226EMD1	23226EMKD1	150	144	216	203	3	0.32	2.12	3.15	2.07	13.8	13.4	
22326EAD1	22326EAKD1	164	147	263	243	4	0.33	2.06	3.06	2.01	27.2	26.6	
22326EMD1	22326EMKD1	164	147	263	243	4	0.33	2.06	3.06	2.01	28.0	27.5	

ULTAGE Series Spherical Roller Bearings [Type EA, Type EM]

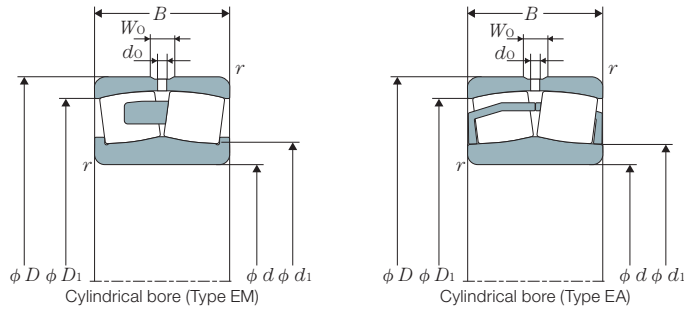

d	Basic Dimensions					Basic Dynamic Load Rating Cr	Basic Static Load Rating Cor	Basic Dynamic Load Rating Cr	Basic Static Load Rating Cor	Permitted Rotational Speed					
	mm									kN		kgf		min ⁻¹	
	D	B	r _{s min} ^②	Wo	do					Cr	Cor	Cr	Cor	Grease Lubrication	Oil Lubrication
140	210	53	2	9	4	597	783	60 900	79 800	2 100	2 700				
	210	53	2	9	4	597	783	60 900	79 800	2 100	2 700				
	210	69	2	9	4	709	990	72 300	101 000	1 800	2 200				
	225	68	2.1	11	5	802	1 030	81 800	105 000	1 800	2 200				
	225	68	2.1	11	5	802	1 030	81 800	105 000	1 800	2 200				
	225	85	2.1	10	4.5	951	1 280	97 000	130 000	1 700	2 200				
	250	68	3	14	7	912	1 010	93 000	103 000	2 000	2 500				
	250	68	3	14	7	912	1 010	93 000	103 000	2 000	2 500				
	250	88	3	13	6	1 140	1 370	116 000	139 000	1 600	2 100				
	300	102	4	19	9	1 540	1 720	157 000	175 000	1 500	1 900				
300	102	4	19	9	1 540	1 720	157 000	175 000	1 500	1 900					
150	225	56	2.1	10	4.5	660	893	67 300	91 100	2 000	2 500				
	225	56	2.1	10	4.5	660	893	67 300	91 100	2 000	2 500				
	225	75	2.1	10	4.5	789	1 140	80 400	116 000	1 700	2 100				
	250	80	2.1	13	6	1 060	1 350	108 000	138 000	1 600	2 000				
	250	80	2.1	13	6	1 060	1 350	108 000	138 000	1 600	2 000				
	250	100	2.1	12	6	1 180	1 590	121 000	162 000	1 600	2 000				
	270	73	3	15	7	1 080	1 220	110 000	124 000	1 800	2 300				
	270	73	3	15	7	1 080	1 220	110 000	124 000	1 800	2 300				
	270	96	3	14	6	1 340	1 620	137 000	165 000	1 500	1 900				
	320	108	4	20	9	1 740	1 890	178 000	193 000	1 400	1 700				
160	220	45	2	9	4	455	683	46 400	69 600	1 900	2 400				
	240	60	2.1	11	5	748	1 000	76 300	102 000	1 800	2 300				
	240	60	2.1	11	5	748	1 000	76 300	102 000	1 800	2 300				
	240	80	2.1	10	5	901	1 290	91 900	132 000	1 600	2 000				
	270	86	2.1	14	6	1 220	1 580	124 000	162 000	1 500	1 900				
	270	86	2.1	14	6	1 220	1 580	124 000	162 000	1 500	1 900				
	270	109	2.1	14	6	1 360	1 860	139 000	190 000	1 500	1 800				
	290	80	3	17	8	1 220	1 390	124 000	142 000	1 700	2 100				
	290	80	3	17	8	1 220	1 390	124 000	142 000	1 700	2 100				
	290	104	3	15	7	1 550	1 890	158 000	193 000	1 400	1 800				
	340	114	4	20	10	1 950	2 210	199 000	226 000	1 300	1 600				
170	230	45	2	9	4.5	468	723	47 700	73 700	1 800	2 300				
	260	67	2.1	12	5	914	1 240	93 200	127 000	1 700	2 200				
	260	67	2.1	12	5	914	1 240	93 200	127 000	1 700	2 200				
	260	90	2.1	11	5	1 100	1 600	112 000	163 000	1 500	1 900				
	280	88	2.1	14	6	1 270	1 700	129 000	173 000	1 400	1 800				
	280	88	2.1	14	6	1 270	1 700	129 000	173 000	1 400	1 800				
	280	109	2.1	14	6	1 410	1 990	144 000	203 000	1 400	1 700				
	310	86	4	18	8	1 400	1 610	143 000	164 000	1 600	2 000				
	310	110	4	16	8	1 700	2 070	173 000	211 000	1 300	1 700				
	360	120	4	20	10	2 200	2 630	225 000	268 000	1 200	1 500				

① Items marked 'K' indicate bearings with a bore taper ratio of 1/12, and items marked 'K30' indicate bearings with a bore taper ratio of 1/30. ② Indicates the minimum allowed chamfer dimension r*.

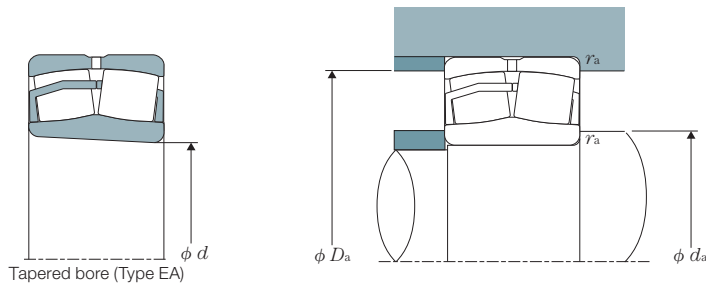

Dynamic equivalent radial load

$$P_r = XF_r + YF_a$$

$\frac{F_a}{F_r} \leq e$		$\frac{F_a}{F_r} > e$	
X	Y	X	Y
1	Y_1	0.67	Y_2

Static equivalent radial load

$$P_{0r} = F_r + Y_0 F_a$$

e , Y_1 , Y_2 and Y_0 are obtained from the tables below.

Part Number		Installation Dimensions					Constant	Axial Load Coefficient			Weight (Ref.)	
Cylindrical Bore	Tapered Bore [®]	d_1	$d_{a \text{ min}}$	$D_{a \text{ max}}$	D_1	$r_{as \text{ max}}$	e	Y_1	Y_2	Y_0	kg	
											Cylindrical Bore	Tapered Bore
23028EAD1	23028EAKD1	155	149	201	193	2	0.22	3.14	4.67	3.07	6.32	6.13
23028EMD1	23028EMKD1	155	149	201	193	2	0.22	3.14	4.67	3.07	6.37	6.18
24028EMD1	24028EMK30D1	153	149	201	188	2	0.28	2.37	3.53	2.32	8.27	8.15
23128EAD1	23128EAKD1	159	152	213	203	2.1	0.26	2.55	3.80	2.50	10.3	9.94
23128EMD1	23128EMKD1	159	152	213	203	2.1	0.26	2.55	3.80	2.50	10.3	10.0
24128EMD1	24128EMK30D1	156	152	213	198	2.1	0.34	1.98	2.94	1.93	12.9	12.8
22228EAD1	22228EAKD1	163	154	236	224	3	0.25	2.74	4.08	2.68	13.9	13.6
22228EMD1	22228EMKD1	163	154	236	224	3	0.25	2.74	4.08	2.68	14.2	13.9
23228EMD1	23228EMKD1	162	154	236	220	3	0.33	2.06	3.06	2.01	18.2	17.7
22328EAD1	22328EAKD1	181	157	283	261	4	0.33	2.03	3.02	1.98	34.4	33.7
22328EMD1	22328EMKD1	181	157	283	261	4	0.33	2.03	3.02	1.98	35.4	34.7
23030EAD1	23030EAKD1	167	161	214	207	2.1	0.21	3.20	4.77	3.13	7.68	7.45
23030EMD1	23030EMKD1	167	161	214	207	2.1	0.21	3.20	4.77	3.13	7.73	7.50
24030EMD1	24030EMK30D1	165	161	214	202	2.1	0.29	2.32	3.45	2.26	10.4	10.3
23130EAD1	23130EAKD1	171	162	238	223	2.1	0.29	2.35	3.50	2.30	15.7	15.2
23130EMD1	23130EMKD1	171	162	238	223	2.1	0.29	2.35	3.50	2.30	15.8	15.3
24130EMD1	24130EMK30D1	168	162	238	216	2.1	0.36	1.85	2.76	1.81	19.7	19.4
22230EAD1	22230EAKD1	177	164	256	242	3	0.25	2.74	4.08	2.68	17.6	17.3
22230EMD1	22230EMKD1	177	164	256	242	3	0.25	2.74	4.08	2.68	18.0	17.7
23230EMD1	23230EMKD1	174	164	256	237	3	0.33	2.03	3.02	1.98	23.6	22.9
22330EMD1	22330EMKD1	188	167	303	279	4	0.34	2.00	2.98	1.96	42.2	41.3
23932EMD1	23932EMKD1	175	169	211	205	2	0.17	3.90	5.81	3.81	5.09	4.94
23032EAD1	23032EAKD1	177	171	229	221	2.1	0.21	3.20	4.77	3.13	9.32	9.03
23032EMD1	23032EMKD1	177	171	229	221	2.1	0.21	3.20	4.77	3.13	9.37	9.09
24032EMD1	24032EMK30D1	175	171	229	215	2.1	0.29	2.32	3.45	2.26	12.6	12.4
23132EAD1	23132EAKD1	185	172	258	240	2.1	0.29	2.35	3.50	2.30	20.1	19.5
23132EMD1	23132EMKD1	185	172	258	240	2.1	0.29	2.35	3.50	2.30	20.2	19.6
24132EMD1	24132EMK30D1	181	172	258	232	2.1	0.37	1.83	2.72	1.79	25.4	25.1
22232EAD1	22232EAKD1	190	174	276	260	3	0.25	2.69	4.00	2.63	22.3	21.8
22232EMD1	22232EMKD1	190	174	276	260	3	0.25	2.69	4.00	2.63	22.9	22.4
23232EMD1	23232EMKD1	187	174	276	254	3	0.33	2.03	3.02	1.98	29.6	28.8
22332EMD1	22332EMKD1	205	177	323	296	4	0.33	2.03	3.02	1.98	50.5	49.5
23934EMD1	23934EMKD1	185	179	221	215	2	0.16	4.11	6.12	4.02	5.39	5.23
23034EAD1	23034EAKD1	190	181	249	238	2.1	0.22	3.07	4.57	3.00	12.7	12.3
23034EMD1	23034EMKD1	190	181	249	238	2.1	0.22	3.07	4.57	3.00	12.8	12.4
24034EMD1	24034EMK30D1	186	181	249	231	2.1	0.30	2.23	3.32	2.18	17.2	16.9
23134EAD1	23134EAKD1	195	182	268	250	2.1	0.28	2.39	3.56	2.34	21.5	20.9
23134EMD1	23134EMKD1	195	182	268	250	2.1	0.28	2.39	3.56	2.34	21.6	20.9
24134EMD1	24134EMK30D1	193	182	268	243	2.1	0.35	1.91	2.85	1.87	26.7	26.3
22234EMD1	22234EMKD1	201	187	293	277	4	0.26	2.60	3.87	2.54	28.3	27.7
23234EMD1	23234EMKD1	199	187	293	272	4	0.33	2.03	3.02	1.98	35.8	34.8
22334EMD1	22334EMKD1	223	187	343	313	4	0.32	2.09	3.11	2.04	60.3	59.1

ULTAGE Series Spherical Roller Bearings [Type EA, Type EM]

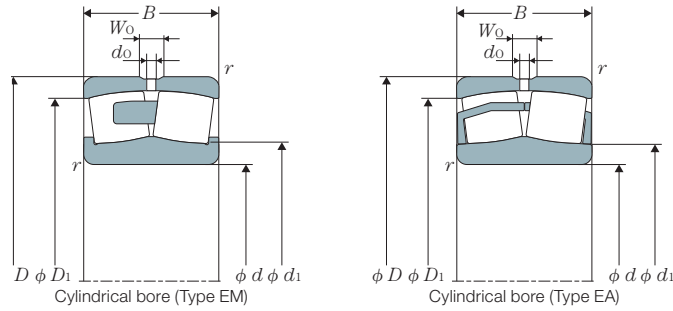

d	Basic Dimensions					Basic Dynamic Load Rating	Basic Static Load Rating	Basic Dynamic Load Rating	Basic Static Load Rating	Permitted Rotational Speed					
	mm									kN		kgf		min ⁻¹	
	D	B	r _s min ^②	Wo	do					Cr	Cor	Cr	Cor	Grease Lubrication	Oil Lubrication
180	250	52	2	10	5	573	869	58 400	88 600	1 700	2 100				
	280	74	2.1	13	6	1 080	1 450	110 000	148 000	1 600	2 000				
	280	74	2.1	13	6	1 080	1 450	110 000	148 000	1 600	2 000				
	280	100	2.1	13	6	1 310	1 880	133 000	192 000	1 400	1 800				
	300	96	3	15	7	1 490	1 960	152 000	200 000	1 300	1 700				
	300	96	3	15	7	1 490	1 960	152 000	200 000	1 300	1 700				
	300	118	3	15	7	1 660	2 290	169 000	233 000	1 300	1 600				
	320	86	4	18	8	1 450	1 660	148 000	169 000	1 500	1 900				
	320	112	4	16	8	1 800	2 270	183 000	231 000	1 200	1 600				
	380	126	4	21	10	2 420	2 810	247 000	286 000	1 100	1 400				
190	260	52	2	10	5	603	935	61 500	95 400	1 600	2 000				
	290	75	2.1	13	6	1 140	1 570	116 000	160 000	1 500	1 900				
	290	75	2.1	13	6	1 140	1 570	116 000	160 000	1 500	1 900				
	290	100	2.1	13	6	1 360	2 000	138 000	204 000	1 300	1 700				
	320	104	3	17	8	1 670	2 250	170 000	230 000	1 200	1 600				
	320	128	3	16	8	1 900	2 700	194 000	275 000	1 200	1 500				
	340	92	4	20	9	1 620	1 870	165 000	191 000	1 400	1 800				
	340	120	4	18	8	1 990	2 480	203 000	253 000	1 200	1 500				
	400	132	5	21	10	2 600	3 120	265 000	318 000	1 000	1 300				
200	280	60	2.1	12	6	766	1 190	78 100	121 000	1 500	1 900				
	310	82	2.1	15	7	1 310	1 790	134 000	182 000	1 400	1 800				
	310	109	2.1	14	7	1 570	2 280	160 000	233 000	1 200	1 600				
	340	112	3	18	8	1 890	2 510	192 000	256 000	1 100	1 400				
	340	140	3	17	8	2 130	2 930	218 000	299 000	1 100	1 400				
	360	98	4	20	10	1 810	2 100	184 000	214 000	1 400	1 700				
	360	128	4	19	9	2 250	2 840	230 000	290 000	1 100	1 300				
	420	138	5	21	10	2 830	3 530	289 000	360 000	950	1 200				
220	300	60	2.1	12	6	789	1 260	80 500	128 000	1 400	1 700				
	340	90	3	15	7	1 530	2 110	156 000	215 000	1 300	1 600				
	340	118	3	15	7	1 850	2 720	189 000	278 000	1 100	1 400				
	370	120	4	19	9	2 190	2 940	223 000	300 000	1 000	1 300				
	370	150	4	19	9	2 540	3 620	259 000	369 000	1 000	1 300				
	400	108	4	21	11	2 210	2 690	225 000	274 000	1 200	1 500				
	400	144	4	20	10	2 890	3 830	295 000	391 000	1 000	1 200				
240	320	60	2.1	12	6	815	1 350	83 100	138 000	1 300	1 600				
	360	92	3	16	8	1 630	2 350	166 000	240 000	1 100	1 400				
	360	118	3	16	8	1 940	2 980	198 000	304 000	1 000	1 300				
	400	128	4	20	9	2 510	3 500	256 000	357 000	960	1 200				
	400	160	4	19	9	2 910	4 290	297 000	438 000	960	1 200				
260	360	75	2.1	14	7	1 130	1 940	115 000	198 000	1 100	1 400				
	400	104	4	18	8	2 060	2 910	210 000	297 000	1 000	1 300				
	400	140	4	18	8	2 520	3 820	257 000	390 000	960	1 200				
280	380	75	2.1	14	7	1 180	2 050	120 000	209 000	1 000	1 300				
	420	106	4	18	8	2 170	3 150	221 000	321 000	960	1 200				
	420	140	4	18	8	2 620	4 060	267 000	414 000	880	1 100				

① Items marked 'K' indicate bearings with a bore taper ratio of 1/12, and items marked 'K30' indicate bearings with a bore taper ratio of 1/30. ② Indicates the minimum allowed chamfer dimension r.

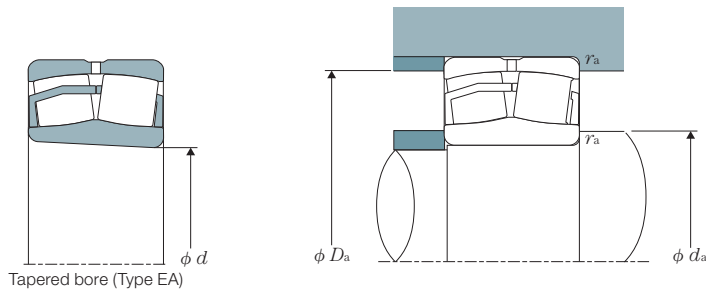

Dynamic equivalent radial load

$$P_r = XF_r + YF_a$$

$\frac{F_a}{F_r} \leq e$		$\frac{F_a}{F_r} > e$	
X	Y	X	Y
1	Y_1	0.67	Y_2

Static equivalent radial load

$$P_{or} = F_r + Y_0 F_a$$

e , Y_1 , Y_2 and Y_0 are obtained from the tables below.

Part Number		Installation Dimensions						Constant	Axial Load Coefficient			Weight (Ref.) kg	
Cylindrical Bore	Tapered Bore [®]	d_1	$d_{a \text{ min}}$	$D_{a \text{ max}}$	D_1	$r_{as \text{ max}}$	e	Y_1	Y_2	Y_0	Cylindrical Bore	Tapered Bore	
23936EMD1	23936EMKD1	199	189	241	232	2	0.17	3.90	5.81	3.81	7.79	7.56	
23036EAD1	23036EAKD1	201	191	269	255	2.1	0.23	2.95	4.40	2.89	16.8	16.3	
23036EMD1	23036EMKD1	201	191	269	255	2.1	0.23	2.95	4.40	2.89	16.9	16.4	
24036EMD1	24036EMK30D1	199	191	269	248	2.1	0.31	2.15	3.20	2.10	22.8	22.4	
23136EAD1	23136EAKD1	205	194	286	267	3	0.29	2.32	3.45	2.26	27.2	26.4	
23136EMD1	23136EMKD1	205	194	286	267	3	0.29	2.32	3.45	2.26	27.4	26.5	
24136EMD1	24136EMK30D1	202	194	286	259	3	0.36	1.87	2.79	1.83	33.5	33.0	
22236EMD1	22236EMKD1	209	197	303	287	4	0.25	2.74	4.08	2.68	29.3	28.7	
23236EMD1	23236EMKD1	210	197	303	282	4	0.33	2.06	3.06	2.01	38.2	37.1	
22336EMD1	22336EMKD1	229	197	363	329	4	0.32	2.09	3.11	2.04	70.2	68.7	
23938EMD1	23938EMKD1	209	199	251	243	2	0.17	4.05	6.04	3.96	8.20	7.96	
23038EAD1	23038EAKD1	213	201	279	266	2.1	0.22	3.01	4.48	2.94	17.8	17.3	
23038EMD1	23038EMKD1	213	201	279	266	2.1	0.22	3.01	4.48	2.94	17.9	17.4	
24038EMD1	24038EMK30D1	209	201	279	258	2.1	0.30	2.23	3.32	2.18	23.8	23.4	
23138EMD1	23138EMKD1	221	204	306	284	3	0.29	2.32	3.45	2.26	34.3	33.2	
24138EMD1	24138EMK30D1	216	204	306	275	3	0.37	1.84	2.74	1.80	42.1	41.5	
22238EMD1	22238EMKD1	222	207	323	305	4	0.25	2.74	4.08	2.68	35.6	34.9	
23238EMD1	23238EMKD1	220	207	323	299	4	0.33	2.03	3.02	1.98	46.1	44.7	
22338EMD1	22338EMKD1	247	210	380	346	5	0.32	2.12	3.15	2.07	81.5	79.9	
23940EMD1	23940EMKD1	221	211	269	260	2.1	0.18	3.76	5.59	3.67	12.0	11.6	
23040EMD1	23040EMKD1	223	211	299	283	2.1	0.23	2.95	4.40	2.89	22.8	22.1	
24040EMD1	24040EMK30D1	221	211	299	275	2.1	0.31	2.18	3.24	2.13	30.2	29.7	
23140EMD1	23140EMKD1	231	214	326	301	3	0.30	2.25	3.34	2.20	41.9	40.6	
24140EMD1	24140EMK30D1	224	214	326	291	3	0.39	1.74	2.59	1.70	51.5	50.7	
22240EMD1	22240EMKD1	234	217	343	323	4	0.25	2.74	4.08	2.68	42.7	41.8	
23240EMD1	23240EMKD1	232	217	343	315	4	0.34	1.98	2.94	1.93	55.2	53.6	
22340EMD1	22340EMKD1	265	220	400	364	5	0.31	2.15	3.20	2.10	94.6	92.7	
23944EMD1	23944EMKD1	241	231	289	280	2.1	0.17	4.05	6.04	3.96	12.5	12.1	
23044EMD1	23044EMKD1	246	233	327	310	3	0.23	2.95	4.40	2.89	29.9	29.1	
24044EMD1	24044EMK30D1	243	233	327	302	3	0.31	2.20	3.27	2.15	39.2	38.6	
23144EMD1	23144EMKD1	252	237	353	328	4	0.30	2.28	3.39	2.23	52.3	50.7	
24144EMD1	24144EMK30D1	247	237	353	317	4	0.38	1.78	2.65	1.74	65.2	64.3	
22244EMD1	22244EMKD1	264	237	383	358	4	0.25	2.74	4.08	2.68	59.6	58.4	
23244EMD1	23244EMKD1	261	237	383	349	4	0.34	2.00	2.98	1.96	79.4	77.1	
23948EMD1	23948EMKD1	262	251	309	301	2.1	0.15	4.40	6.56	4.31	13.5	13.1	
23048EMD1	23048EMKD1	267	253	347	329	3	0.22	3.07	4.57	3.00	32.0	31.7	
24048EMD1	24048EMK30D1	264	253	347	322	3	0.28	2.37	3.53	2.32	42.2	41.6	
23148EMD1	23148EMKD1	276	257	383	356	4	0.29	2.32	3.45	2.26	65.1	63.1	
24148EMD1	24148EMK30D1	270	257	383	344	4	0.37	1.82	2.70	1.78	81.0	79.8	
23952EMD1	23952EMKD1	292	271	349	335	2.1	0.17	3.90	5.81	3.81	23.9	23.1	
23052EMD1	23052EMKD1	291	275	385	366	4	0.23	2.95	4.40	2.89	47.8	46.3	
24052EMD1	24052EMK30D1	286	275	385	354	4	0.31	2.16	3.22	2.12	63.6	62.6	
23956EMD1	23956EMKD1	310	291	369	356	2.1	0.16	4.16	6.20	4.07	25.2	24.4	
23056EMD1	23056EMKD1	310	295	405	386	4	0.22	3.07	4.57	3.00	51.3	49.7	
24056EMD1	24056EMK30D1	306	295	405	376	4	0.29	2.30	3.42	2.25	67.3	66.3	

ULTAGE Series Sealed Spherical Roller Bearings [Type WA]

Bearing Number

WA	222	20	EA	LLS	K	D1	C3
-----------	------------	-----------	-----------	------------	----------	-----------	-----------

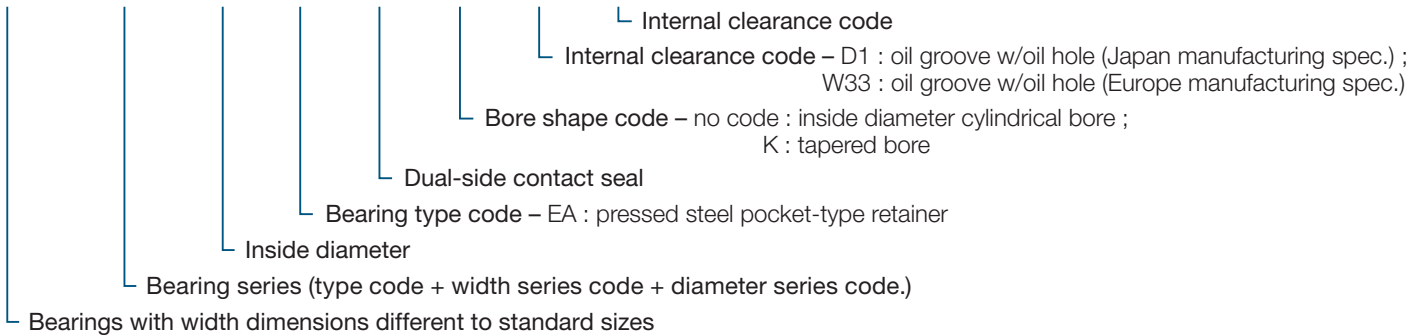

Basic Dimensions						Basic Dynamic Load Rating	Basic Static Load Rating	Basic Dynamic Load Rating	Basic Static Load Rating	Part Number	
mm						kN		kgf		Cylindrical Bore	Tapered Bore ^①
<i>d</i>	<i>D</i>	<i>B</i>	<i>r_{s min}</i> ^②	<i>W_o</i>	<i>d_o</i>	<i>C_r</i>	<i>C_{or}</i>	<i>C_r</i>	<i>C_{or}</i>		
25	52	23	1	3	1.5	57.3	46.1	5 840	4 700	WA22205EALLSW33	—
30	62	25	1	4	2	75.7	64.5	7 720	6 580	WA22206EALLSW33	—
35	72	28	1.1	5	2	100	92	10 200	9 380	WA22207EALLSW33	WA22207EALLSKW33
40	80	28	1.1	5	2.5	116	105	11 800	10 700	WA22208EALLSD1	WA22208EALLSKD1
45	85	28	1.1	6	2.5	121	113	12 300	11 500	WA22209EALLSD1	WA22209EALLSKD1
50	90	28	1.1	6	2.5	130	124	13 300	12 600	WA22210EALLSD1	WA22210EALLSKD1
55	100	31	1.5	6	3	155	148	15 800	15 100	WA22211EALLSD1	WA22211EALLSKD1
60	110	34	1.5	7	3	187	181	19 100	18 400	WA22212EALLSD1	WA22212EALLSKD1
65	120	38	1.5	8	3.5	226	224	23 100	22 900	WA22213EALLSD1	WA22213EALLSKD1
70	125	38	1.5	7	3.5	235	240	24 000	24 400	WA22214EALLSD1	WA22214EALLSKD1
75	130	38	1.5	7	3.5	244	249	24 800	25 400	WA22215EALLSD1	WA22215EALLSKD1
80	140	40	2	8	3.5	278	287	28 400	29 300	WA22216EALLSD1	WA22216EALLSKD1
85	150	44	2	8	3.5	324	330	33 000	33 600	WA22217EALLSD1	WA22217EALLSKD1
90	160	48	2	10	4.5	384	398	39 200	40 600	WA22218EALLSD1	WA22218EALLSKD1
100	180	55	2.1	11	5	472	495	48 100	50 500	WA22220EALLSD1	WA22220EALLSKD1
110	200	63	2.1	12	6	602	643	61 400	65 600	WA22222EALLSD1	WA22222EALLSKD1
120	215	69	2.1	12	6	688	753	70 100	76 800	WA22224EALLSD1	WA22224EALLSKD1
130	230	75	3	13	6	808	898	82 400	91 600	WA22226EALLSD1	WA22226EALLSKD1

① Indicates bearings with a bore taper ratio of 1/12. ② Indicates the minimum allowed chamfer dimension *r**.

Caution when handling bearings

1. Because the internal radial clearance of "ULTAGE Series Sealed Spherical Roller Bearings" with tapered bores cannot be measured with a thickness gauge, please monitor clearances by measuring the axial movement of the inner ring as shown in Table 1.
2. During assembly, if misalignment exceeding the allowable misalignment angle of $\pm 0.5^\circ$ is applied to the bearing, rollers may come in direct contact with seals causing seal deformation. Furthermore, if additional force is applied under these conditions, seals may separate from the bearing entirely. Therefore, caution is advised.
3. Please use Lithium mineral grease. In case other types of grease are to be used, please consult **NTN**.
4. If a shrink fit is to be applied, please do not exceed a bearing temperature of 100°C. However, these bearing cannot be shrink fit via immersion in a hot oil bath.

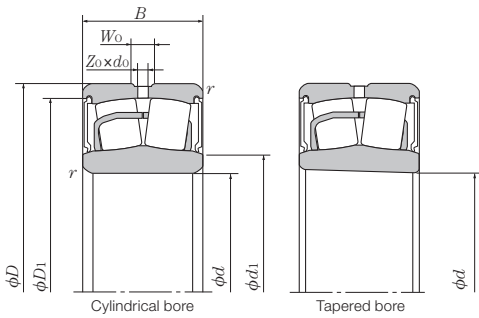

Number of outer ring oil holes

Z _o	
D1	W33
4	3

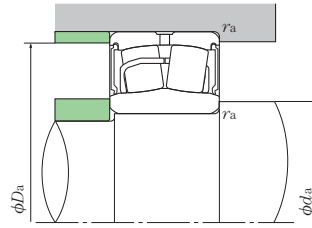

Dynamic equivalent radial load

$$P_r = XF_r + YF_a$$

$\frac{F_a}{F_r} \leq e$		$\frac{F_a}{F_r} > e$	
X	Y	X	Y
1	Y ₁	0.67	Y ₂

Static equivalent radial load

$$P_{or} = F_r + Y_0 F_a$$

e, *Y*₁, *Y*₂ and *Y*₀ are obtained from the tables below.

Installation Dimensions					Constant	Axial Load Coefficient			Weight (Ref.)		Grease Pack Amount (Ref.)
<i>d</i> ₁	<i>d</i> _{a min}	<i>D</i> _{a max}	<i>D</i> ₁	<i>r</i> _{as max}	<i>e</i>	<i>Y</i> ₁	<i>Y</i> ₂	<i>Y</i> ₀	kg Cylindrical Bore	kg Tapered Bore	g
29	29	47	47	1	0.34	2.00	2.98	1.96	0.19	—	1.4 ~ 2.4
36	36	56	56	1	0.31	2.15	3.20	2.10	0.30	—	2.0 ~ 3.3
43	42	65	65	1.1	0.31	2.21	3.29	2.16	0.50	0.49	2.3 ~ 3.9
48	47	73	73	1.1	0.27	2.47	3.67	2.41	0.58	0.57	3.1 ~ 5.2
53	52	78	78	1.1	0.26	2.64	3.93	2.58	0.63	0.61	3.4 ~ 5.7
58	57	83	83	1.1	0.24	2.84	4.23	2.78	0.70	0.68	3.4 ~ 5.6
64	64	93	93	1.5	0.23	2.95	4.40	2.89	0.94	0.91	5.2 ~ 7.9
70	69	102	102	1.5	0.24	2.84	4.23	2.78	1.25	1.22	6.6 ~ 11.0
76	74	111	110	1.5	0.24	2.79	4.15	2.73	1.72	1.67	8.5 ~ 14.2
82	79	116	116	1.5	0.22	3.01	4.48	2.94	1.78	1.73	9.6 ~ 16.0
86	84	121	121	1.5	0.22	3.14	4.67	3.07	1.88	1.83	9.9 ~ 16.4
93	91	131	131	2	0.22	3.14	4.67	3.07	2.32	2.27	12.2 ~ 20.3
98	96	140	140	2	0.22	3.07	4.57	3.00	2.90	2.83	16.9 ~ 28.1
103	101	149	147	2	0.23	2.90	4.31	2.83	3.68	3.59	20.4 ~ 34.1
115	112	168	165	2.1	0.24	2.84	4.23	2.78	5.40	5.25	28.8 ~ 48.0
127	122	188	183	2.1	0.25	2.69	4.00	2.63	7.79	7.58	41.6 ~ 69.3
138	132	203	197	2.1	0.25	2.74	4.08	2.68	9.76	9.48	52.8 ~ 88.0
148	144	216	211	3	0.25	2.69	4.00	2.63	11.9	11.6	62.6 ~ 104.4

Table 1. Installation of Tapered Bore Sealed Spherical Roller Bearings

Units : mm

Nominal Bearing Inside Diameter <i>d</i>		Radial Internal Clearance Reduction		Axial Displacement Drive-up		Minimum Residual Radial Internal Clearance		
Greater Than	Equal to or Less Than	Min.	Max.	Min.	Max.	CN	C3	C4
24	30	0.010	0.015	0.15	0.20	0.015	0.025	0.040
30	40	0.015	0.020	0.25	0.30	0.015	0.030	0.045
40	50	0.020	0.025	0.35	0.40	0.020	0.035	0.055
50	65	0.025	0.030	0.40	0.45	0.025	0.045	0.065
65	80	0.035	0.040	0.50	0.60	0.030	0.055	0.080
80	100	0.040	0.050	0.60	0.70	0.030	0.060	0.090
100	120	0.055	0.065	0.80	0.90	0.035	0.070	0.105
120	130	0.065	0.075	0.90	1.00	0.045	0.085	0.125

Triple-Lip Sealed Bearings for Bearing Units

Bearing Number

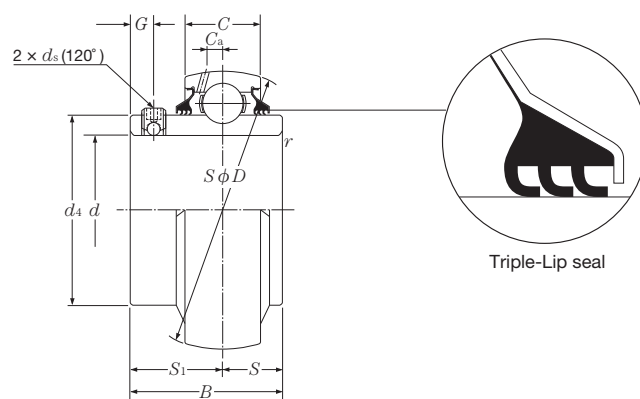
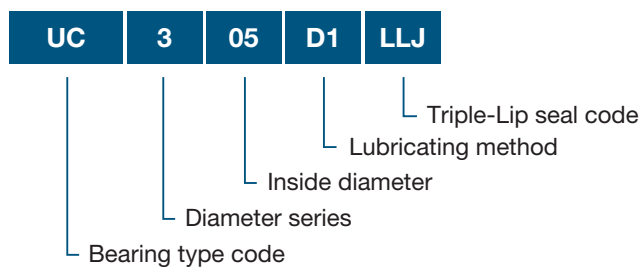

Shaft Diameter mm	Part Number	Dimensions mm											Basic Dynamic Load Rating kN	Basic Static Load Rating kN	Coefficient <i>f_o</i>	Bearing Weight kg (Ref.)
		<i>d</i>	<i>D</i>	<i>B</i>	<i>C</i>	<i>r_{s min}</i> ^①	<i>S</i>	<i>S₁</i>	<i>G</i>	<i>ds</i>	<i>Ca</i>	<i>d₄</i>				
12	UC201D1LLJ	12	47	31	17	0.6	12.7	18.3	4.5	M 5 × 0.8	3.8	29.6	12.8	6.65	13.2	0.21
15	UC202D1LLJ	15	47	31	17	0.6	12.7	18.3	4.5	M 5 × 0.8	3.8	29.6	12.8	6.65	13.2	0.20
17	UC203D1LLJ	17	47	31	17	0.6	12.7	18.3	4.5	M 5 × 0.8	3.8	29.6	12.8	6.65	13.2	0.18
20	UC204D1LLJ	20	47	31	17	1	12.7	18.3	4.5	M 5 × 0.8	3.8	29.6	12.8	6.65	13.2	0.17
25	UC205D1LLJ	25	52	34.1	17	1	14.3	19.8	5	M 5 × 0.8	4	33.9	14.0	7.85	13.9	0.20
30	UC206D1LLJ	30	62	38.1	19	1	15.9	22.2	5	M 6 × 0.75	4.9	40.8	19.5	11.3	13.8	0.32
35	UC207D1LLJ	35	72	42.9	20	1.5	17.5	25.4	6	M 6 × 0.75	5.4	46.8	25.7	15.3	13.8	0.46
40	UC208D1LLJ	40	80	49.2	21	1.5	19	30.2	8	M 8 × 1	6	53	29.1	17.8	14.0	0.64
45	UC209D1LLJ	45	85	49.2	22	1.5	19	30.2	8	M 8 × 1	6.1	57.5	32.5	20.4	14.1	0.68
50	UC210D1LLJ	50	90	51.6	24	1.5	19	32.6	9	M 8 × 1	6.1	62.4	35.0	23.2	14.4	0.78
55	UC211D1LLJ	55	100	55.6	25	2	22.2	33.4	9	M 8 × 1	6.5	69	43.5	29.2	14.3	1.04
60	UC212D1LLJ	60	110	65.1	27	2	25.4	39.7	10	M10 × 1.25	7.3	77	52.5	36.0	14.3	1.46
65	UC213D1LLJ	65	120	65.1	32	2	25.4	39.7	10	M10 × 1.25	7.3	82.5	57.5	40.0	14.4	1.86
70	UC214D1LLJ	70	125	74.6	33	2	30.2	44.4	12	M10 × 1.25	7.7	87	62.0	44.0	14.5	2.10
75	UC215D1LLJ	75	130	77.8	34	2	33.3	44.5	12	M10 × 1.25	8	93	66.0	49.5	14.7	2.34
80	UC216D1LLJ	80	140	82.6	35	2.5	33.3	49.3	12	M10 × 1.25	8	98.1	72.5	53.0	14.6	2.78
85	UC217D1LLJ	85	150	85.7	36	2.5	34.1	51.6	12	M12 × 1.5	7.9	106.4	83.5	64.0	14.7	3.54
90	UC218D1LLJ	90	160	96	37	2.5	39.7	56.3	12	M12 × 1.5	8.7	111.6	96.0	71.5	14.5	4.40

① Indicates the minimum allowed chamfer dimension *r*.

Note 1 : Refer to the related Bearing Units catalog (Cat. No. 2400) for the shaft size tolerances.

2 : The precision of the ball bearings is identical to JIS B1558 (ball bearings for rolling bearings units).

3 : Contact **NTN** for inch size shaft dimensions and tapered bore style.

Size Charts

ULTAGE

ULTAGE Series Thrust Spherical Roller Bearings

Bearing Number

294 20 E

└ Bearing type code

└ Inside diameter

└ Bearing series (type code + height series code + diameter series code.)

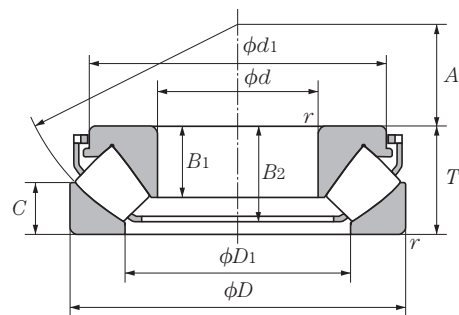

Part Number	Basic Dimensions mm				$r_s \text{ min}^{\text{①}}$	Basic Dynamic Load Rating kN		Basic Static Load Rating kgf		Permitted Rotational Speed min^{-1}	
	d	D	T			C_a	C_{oa}	C_a	C_{oa}	Oil Lubrication	Grease Lubrication
29412E	60	130	42	0.5	451	928	45 900	94 700	3 050	1 650	
29413E	65	140	45	2	531	1 120	54 200	114 000	2 850	1 530	
29414E	70	150	48	2	608	1 290	62 000	132 000	2 650	1 420	
29415E	75	160	51	2	675	1 470	68 800	150 000	2 500	1 330	
29416E	80	170	54	2.1	788	1 690	80 400	173 000	2 350	1 250	
29417E	85	180	58	2.1	820	1 860	83 600	190 000	2 200	1 170	
29418E	90	190	60	2.1	934	2 050	95 200	209 000	2 100	1 110	
29420E	100	210	67	3	1 170	2 570	119 000	262 000	1 850	1 000	
29422E	110	230	73	3	1 380	3 100	141 000	316 000	1 700	900	
29424E	120	250	78	4	1 520	3 550	155 000	362 000	1 550	830	
29426E	130	270	85	4	1 770	4 270	181 000	435 000	1 450	760	
29428E	140	280	85	4	1 850	4 350	188 000	443 000	1 400	710	
29430E	150	300	90	4	2 200	5 270	225 000	537 000	1 300	660	
29432E	160	320	95	5	2 410	5 790	246 000	590 000	1 200	620	

① Indicates the minimum allowed chamfer dimension r .

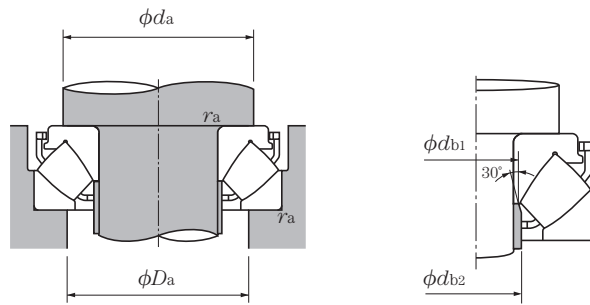

Dynamic equivalent axial load

$$P_a = F_a + 1.2Fr$$

Static equivalent axial load

$$P_{oa} = F_a + 2.7Fr$$

However, $\frac{Fr}{F_a} \leq 0.55$ is required

	Dimensions mm				Installation Dimensions mm							Weight kg (Ref.)	Static Space Capacity cm ³ (Ref.)
	<i>B</i> ₁	<i>B</i> ₂	<i>C</i>	<i>A</i>	<i>d</i> ₁	<i>d</i> _a Min.	<i>d</i> _{b1} Max.	<i>d</i> _{b2} Max.	<i>D</i> ₁	<i>D</i> _a Max.	<i>r</i> _{as} Max.		
27	37	20.5	38	110	90	65	67	85	108	1.5	2.50	83.2	
29.3	40	22.5	42	116	100	70	72	95	115	2	3.10	98.6	
31.3	43	23.7	44	125	105	75	77	100	125	2	3.75	122	
35.4	46	23.9	47	135	115	79	83	104	132	2	4.56	143	
35.3	49	26.5	50	143	120	87	87	114	140	2	5.47	173	
38.6	51	27.8	54	152	130	92	95	121	150	2	6.54	216	
40.5	55	27	56	162	135	95	102	126	157	2	7.51	251	
44	58.9	32	62	181	150	107	114	141	175	2.5	10.3	340	
48.5	65	35	69	199	165	118	125	156	190	2.5	13.1	439	
52.7	71	35.9	74	218	180	128	135	171	205	3	16.7	563	
58.5	74	39.6	81	238	195	138	146	180	225	3	21.4	695	
56	74.5	42	86	244	205	149	158	196	235	3	22.3	739	
60.5	81	43.2	92	264	220	158	168	204	250	3	27.4	838	
63	84.9	45.5	99	280	230	170	182	221	265	4	32.5	1 050	

Bearing Inspection and Maintenance

● Bearing inspection and maintenance

Performing periodic inspections and maintenance of the bearings makes it possible to maintain the original performance of the bearing for a long time, and also detect any early-stage bearing anomalies. Therefore, inspections and maintenance can increase productivity and economic efficiency by preventing bearing failures before they occur.

The inspection items on the right are generally accepted methods for bearing maintenance and care. Depending on the importance of the system or machinery being used, implementing periodic inspection cycles is an important aspect of bearing maintenance and management.

① Inspect the bearings while the equipment is operating

Check the temperature, sound, and vibration of the bearings. Examine the characteristics of the lubricant and determine the cycle for refilling or replacing the lubricant.

② Visually monitor the bearings

Carefully monitor any visible problems that appear when carrying out periodic inspections after the bearings have been in use. If there are visible signs of damage, take measures to prevent recurrence.

*Bearing Damage – Typical Examples & Causes

Refer to the related catalog : Care and Maintenance of Bearings (Cat. No. 3017) for more details.

Installing Tapered Bore Roller Bearings

● Installing tapered bore roller bearings

Install small-sized bearings by using a tapered shaft, withdrawal sleeve, or adapter sleeve. Secure the bearing by tightening the locking nut. Furthermore, tighten the nut with a mallet or impact spanner (See Fig. 1).

Use hydraulic pressure when installing large-size bearings, which require a greater force. Figure 2 (a) shows the method of pushing the bearing onto a tapered shaft using a hydraulic nut. Figures 2 (b) and (c) show the hydraulic nut installation method when using an adapter sleeve or withdrawal sleeve.

With tapered bore bearings, as the inner ring is driven axially onto the tapered shaft, adapter or withdrawal sleeve, the interference will increase and the bearing internal radial clearance will decrease. Interference can be estimated by measuring the decrease in internal radial clearance.

Figure 3 shows the method for measuring the radial internal clearance of a spherical roller bearing by inserting a feeler gauge (thickness gauge) in between the rollers and the outer ring while the rollers are sitting correctly in a non-load position.

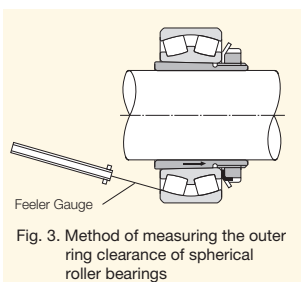

The appropriate interference fit is obtained by pushing in the axial direction until the correct clearance reduction is achieved. It is also possible to measure the distance the bearing has been driven axially from the point of initial contact on the taper to achieve the recommended clearance reduction.

A larger interference fit and bearings with a radial internal clearance of C3 or higher are required when heavy loads are applied, when the bearings are running at high speed, and when there is a large temperature difference between the inner and outer rings. Table 1 shows the maximum values for the radial internal clearance reduction and axial displacement amount used during installation. It is necessary to set the residual clearance above the minimum residual clearance value shown in Table 1.

[Ref.] Table 2 shows an example calculation for determining the nut rotation angle when installing a spherical roller bearing using an adapter sleeve.

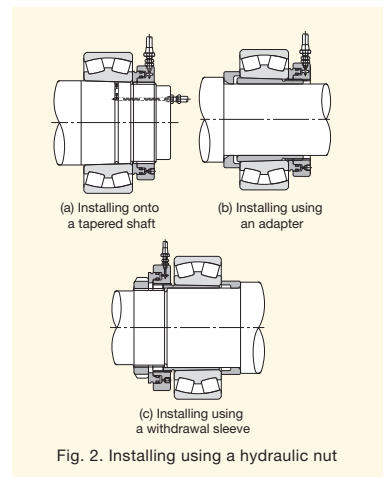
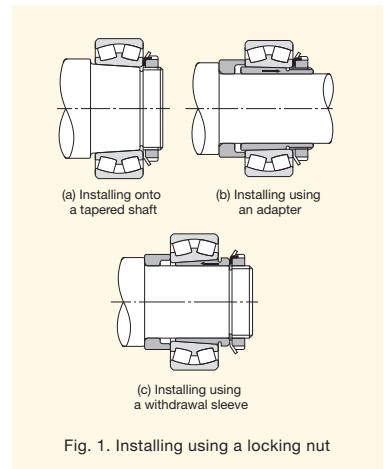

Table 1. Tapered bore spherical roller bearing installation specifications – Type EA/EM

Units : mm

Bearing Inside Diameter d		Radial Internal Clearance (Pre-Installation)						Radial Internal Clearance Reduction		Axial Movement Amount (ref.)				Minimum Residual Radial Internal Clearance		
		CN		C3		C4				1/12		Taper Ratio 1/30				
Greater Than	Equal to or Less Than	Min.	Max.	Min.	Max.	Min.	Max.	Min.	Max.	Min.	Max.	Min.	Max.	CN	C3	C4
24	30	0.030	0.040	0.040	0.055	0.055	0.075	0.010	0.015	0.15	0.20	—	—	0.015	0.025	0.040
30	40	0.035	0.050	0.050	0.065	0.065	0.085	0.015	0.020	0.25	0.30	—	—	0.015	0.030	0.045
40	50	0.045	0.060	0.060	0.080	0.080	0.100	0.020	0.025	0.35	0.40	—	—	0.020	0.035	0.055
50	65	0.055	0.075	0.075	0.095	0.095	0.120	0.025	0.030	0.40	0.45	—	—	0.025	0.045	0.065
65	80	0.070	0.095	0.095	0.120	0.120	0.150	0.035	0.040	0.50	0.60	—	—	0.030	0.055	0.080
80	100	0.080	0.110	0.110	0.140	0.140	0.180	0.040	0.050	0.60	0.70	—	—	0.030	0.060	0.090
100	120	0.100	0.135	0.135	0.170	0.170	0.220	0.055	0.065	0.80	0.90	1.80	2.30	0.035	0.070	0.105
120	140	0.120	0.160	0.160	0.200	0.200	0.260	0.065	0.075	0.90	1.00	1.95	2.70	0.045	0.085	0.125
140	160	0.130	0.180	0.180	0.230	0.230	0.300	0.075	0.090	1.00	1.20	2.35	3.10	0.040	0.090	0.140
160	180	0.140	0.200	0.200	0.260	0.260	0.340	0.080	0.100	1.10	1.40	2.80	3.55	0.040	0.100	0.160
180	200	0.160	0.220	0.220	0.290	0.290	0.370	0.090	0.110	1.20	1.50	3.20	3.95	0.050	0.110	0.180
200	225	0.180	0.250	0.250	0.320	0.320	0.410	0.110	0.130	1.50	1.80	3.85	4.60	0.050	0.120	0.190
225	250	0.200	0.270	0.270	0.350	0.350	0.450	0.120	0.140	1.60	1.90	4.20	4.95	0.060	0.130	0.210
250	280	0.220	0.300	0.300	0.390	0.390	0.490	0.130	0.160	1.60	2.10	4.25	5.40	0.060	0.140	0.230

Note 1 : Applies to solid shaft normal, C3 and C4 clearances

Note 2 : For type 213, refer to the related Ball and Roller Bearings catalog (Cat. No. 2202).

 Note 3 : When clearance C2 and Pr are $> 0.15 Cr$, a separate evaluation is required. Contact NTN for more information.

Table 2. Example calculation for determining the nut rotation angle

Calculation example (approximation)

Conditions

Bearing part number : 22216EAKD1

Inside diameter : 80 mm, outside diameter : 140 mm, width : 33 mm / 1.299"

EA : EA Type, K : bore taper ratio 1/12, D1 : w/lubricant groove/holes

CN clearance : 0.070-0.095 mm

Adapter sleeve : H316X

Nut : M80 × 2 (inside diameter × pitch)

Reference formula

$$\text{Clearance reduction} = \frac{\text{Axial movement amount}}{\text{Taper ratio}} \times \text{Inner ring expansion coefficient}$$

$$\text{Axial movement amount} = \frac{\text{Nut thread pitch} \times \text{nut rotation angle}}{360^\circ}$$

$$\text{Inner ring expansion coefficient} = \frac{\text{Inner ring inside diameter}}{\text{Inner ring average groove diameter}} = \frac{80}{100} = 0.8$$

$$\begin{aligned} \text{Inner ring average groove diameter} &= \frac{2 \times \text{inner ring inside diameter} + \text{outer ring outside diameter}}{3} \\ &= \frac{2 \times 80 + 140}{3} = 100 \text{ mm} \end{aligned}$$

Nut rotation angle calculation

Radial internal clearance reduction (max.) 0.04 mm

$$\text{Clearance after installation} = \text{Initial clearance (measured value)} - \text{clearance reduction} = 0.09 - 0.04 = 0.05 \text{ mm}$$

$$\text{Axial movement amount} = \frac{\text{Clearance reduction} \times \text{taper ratio}}{\text{Inner ring expansion coefficient}} = \frac{0.04 \times 12}{0.8} = 0.6 \text{ mm}$$

$$\text{Nut rotation angle} = \frac{\text{Axial movement amount} \times 360^\circ}{\text{Nut pitch}} = \frac{0.6 \times 360}{2} = 108^\circ$$

Note : For open type bearings, measure the clearances by using a feeler gauge.

Bearing Damage – Typical Examples & Causes

Creep

The inside or outside diameter surface becomes a mirror or cloudy.

[Service]
Press Section

Cause
Insufficient interference fit
Correction
Investigate the interference fit



Inner Ring Breakage

Breaking or cracking occurs.

[Service]
Dryer Section

Cause
Excessive inner ring interference stress, thermal shock, impact, fatigue, poor fitting form
Correction
Investigate the interference fit Use long operating life EA bearings * See page 11



Rust

Rust and corrosion occur on surfaces of raceways and rolling elements.

[Service]
Wire Section, Press Section

Cause
Water penetration, condensation, handling with bare hands
Correction
Improve seal performance Take measures to prevent bearing corrosion during prolonged downtime Utilization of RustGuard Corrosion-Resistant Bearings * See pages 9-10



Flaking (Delamination)

The raceway surface peels away in scale-like flakes.

[Service]

Wire Section, Press Section, Dryer Section



Cause
Excessive load, foreign material penetration
Correction
Change to bearings with a larger load capacity Use of lubricant with a high viscosity

Smearing

Roughening of the raceway surface with minute weld deposits.

[Service]

Calender Stack



Cause
Poor lubricant performance for the rotating motion of the roller elements
Correction
Prevent sliding (reduce the radial internal clearance, consider precompression). Use of lubricant with a high viscosity Use long operating life EA bearings * See pages 11-12

Electrolytic Erosion

Fluting formed by small surface pits across the raceways.

[Service]

Electric Motors

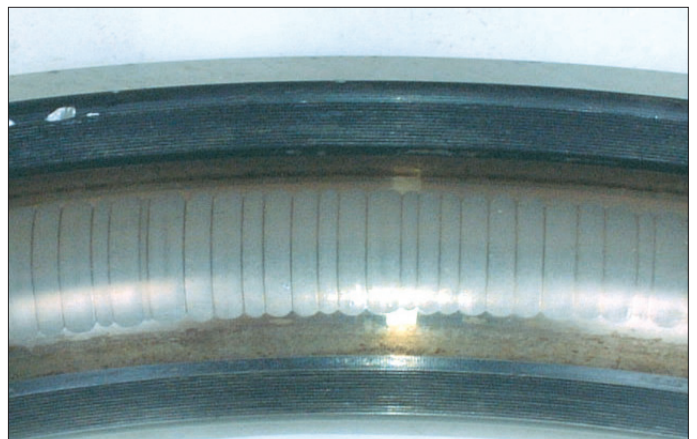

Cause
Raceway surface melting due to electric current conduction and sparking inside the bearing
Correction
Discharge the current via a slip ring, etc. Use MEGAOHM™ Insulated Bearings * See page 15